



REGULAR MEETING – LIBRARY BOARD OF DIRECTORS AGENDA

JUNE 12, 2025, 7:00 PM
BY ZOOM VIRTUAL MEETING

To allow public access, anyone may access a meeting by telephone and/or Zoom, or a recording in the City of Norwalk YouTube channel. Specific instructions and links can be found at norwalkct.gov/meetings.



Members of the public may call in to participate. Callers will not be able to see the meeting participants. All participants will be muted upon entering the meeting. To speak, dial *9 on the phone and you will be called on by the host of the meeting during the public comment section. All speakers must state their name and address. Comments must be on a topic on the agenda, and are limited to three minutes. Anyone disrupting the orderly conduct of the meeting, including by using threatening, hateful, or sexually-explicit language, will be removed. Please find the information using the link above.



Members of the public who wish to provide "live comments" may also use the Zoom meeting platform. All participants will be muted upon entering the meeting. To speak, click the "raise your hand indicator" and you will be called by the host of the meeting during the public comment section. All speakers must state their name and address. Comments must be on a topic on the agenda, and are limited to three minutes. Anyone disrupting the orderly conduct of the meeting, including by using threatening, hateful, or sexually-explicit language, will be removed. Please find the information using the link above.



Members of the public who wish to provide public comment are encouraged to submit those via email in advance of the meeting. For these comments to be included into the record, they must be submitted by 12:00 p.m. the day of the meeting. Please email Sherelle Harris at sharris@norwalkpl.org with the subject line "Public Comment" to provide written public comment prior to the meeting.

- I. **CALL TO ORDER**
- II. **ROLL CALL**
- III. **ACCEPTANCE OF MINUTES**
 - A. **Regular Meeting: DATE**
 - 1. May 8, 2025 Meeting Minutes
- IV. **PUBLIC PARTICIPATION**
- V. **REPORTS**
 - A. **President**
 - 1. Charter Revision

2. Strategic Building Plan

B. Library Director

1. Main Library Parking Lots

2. Capital Project Updates

3. Reinstating Main Library as Polling Site

4. SimplifyCT Probono Tax Preparers Report

VI. OLD BUSINESS

VII. NEW BUSINESS

VIII. ADJOURNMENT

**CITY OF NORWALK
LIBRARY BOARD OF DIRECTORS
REGULAR MEETING
MAY 8, 2025
VIA ZOOM VIRTUAL MEETING**

ATTENDANCE: Moina Noor; Chair, Patsy Brescia; Vice Chair, Alex Knopp, Janie Williams, Haroldo Williams, Mary Mann (7:01 p.m.)

STAFF: Sherelle Harris; Library Director

I. CALL TO ORDER

Ms. Noor called the meeting to order at 7.00 p.m.

II. ROLL CALL

Ms. Noor Called the roll as reflected above.

III. ACCEPTANCE OF MINUTES

A. Regular Meeting: 4.10.25

B. Acceptance of 3.19.25 Special Meeting Minutes

**** MR. KNOPP MOVED TO APPROVE THE MINUTES.**

Ms. Mann joined the meeting at 7:01

**** THE MOTION PASSED WITH FIVE IN FAVOR AND ONE ABSTENSION (MS. MANN).**

IV. PUBLIC PARTICIPATION

There was no one present to comment at this time.

V. REPORTS

A. President

1. Charter Revision Update

Ms. Noor provided an update on the charter revision, reporting on the recent Charter Revision Committee meeting, where both she and Ms. Peterson spoke. Two primary questions were raised: one regarding events at the previous meeting, and another concerning the authority to appoint the Library Board. Ms. Noor noted a shared concern among attendees about safeguarding the Library Board from undue mayoral influence.

She also discussed her conversation with Tyler Fairbairn, Chair of the Charter Revision Committee, emphasizing the importance of protecting the library from external political pressures and maintaining a balance of power.

Ms. Noor referenced a letter from the Association of Connecticut Library Boards in support of the proposed charter change. She stated that the letter, along with examples from other municipal library charters, would be submitted to the committee. Further updates are expected at the next board meeting.

2. Strategic /Building Planning

Ms. Noor had no comments at this time.

B. Library Director

1. Main Library Parking Update

Ms. Harris provided an update on the parking situation. She stated that there are currently three parking lots used for library parking and stated the number of available spaces in each of them. She also noted that there are dedicated spaces at the Yankee Doodle Garage for library staff to park, thanks to the work of the Library Board.

Ms. Harris mentioned that some staff feel unsafe walking to the Yankee Doodle Garage when they work evening hours. As a potential solution, she proposed that staff park there during the day and relocate their vehicles to the Eagles lot after dinner. She stated that there was support for this idea during a community services meeting.

Addressing the Eagles lot, Ms. Harris reported that it currently has 30 spaces, some of which can be allocated for staff use in the evenings. While the goal is to retain all 30 spaces, since the Wall Street Project will no longer need 13 of them, only 17 have been budgeted. Discussions are ongoing to explore funding for the additional 13.

Ms. Brescia noted that up to 20 employees sometimes use the lot and emphasized the importance of maintaining sufficient parking at the Eagles lot, Yankee Doodle Garage, and the Library's own lot.

Ms. Harris reviewed the recent improvements, including signage and striping. She reported that the 3 Belden lot still requires significant work, with striping being the only progress so far. She also stressed the need for directional signage at 3 Belden to prevent accidents and to enhance safety and discussed removing the fence addressing the egress issues between the 3 Belden lot and the library property.

She added that they would follow up on a recommendation to meet with the Parking Authority to revisit the idea of the department managing Library lots.

In response to a question about patron feedback, Ms. Harris said that patrons are generally satisfied unless there is a large program, and many are unaware that the Eagles lot is available.

Ms. Brescia inquired about removing the social distancing markers left over from the COVID-19 pandemic.

In response to Ms. Noor's question about funding the remaining 13 parking spaces, Ms. Harris said that no decision had been made yet.

2. Library Landscaping Update

Ms. Harris reported that funds are available in the budget for landscaping at both library locations. She stated that the Department of Public Works (DPW) is now responsible for snow removal in the parking lots, while a landscaping company handles lawn care. Their services include spring cleanup, plant and flower bed maintenance, debris removal, weekly lawn care, shrub trimming, and fall cleanup. The current contract runs from April through October. Ms. Harris said that they are trying to pinpoint consistency in their coming so that maintenance can plan between their visits.

Ms. Noor asked whether the landscaping company had begun work. Ms. Harris replied that they had not and, to prevent complaints, internal staff had handled mowing. She added that she hoped to have a formal schedule by the following week.

Ms. Harris discussed replanting bushes in the rose garden to help address a mosquito infestation. They had been cut because the maintenance staff said they were infested with mosquitoes that had been a major issue. She noted that their current pest control provider has been ineffective. They are considering hiring Mosquito Swad Plus, which is scheduled to begin treatment on Tuesday, May 13. The Health Department approved their product.

Ms. Brescia inquired about the condition of the drains and whether they had been cleared. Mr. Knopp agreed with her concerns, stating that clogged drains can create ideal mosquito breeding

conditions. He recommended a multi-pronged approach, including the use of larvicide, eliminating standing water, and limited fogging.

Ms. Harris stated that Guarding drops mosquito dunks in drains around the property that have standing water.

Mr. Williams asked whether notice would be given to ensure the area is clear during fogging. Ms. Harris confirmed that fogging would begin at 7 a.m., hours before the library staff enter the building and that mosquito squad staff would notify anyone in the vicinity to vacate the area.

3. Norwalk Poet Laureate Updates

Ms. Harris turned the discussion to the new Poet Laureate. Ms. Harris stated she has formed a mailing list and created several accounts listed below.

Join the Norwalk Poet Laureate's Mailing List

<https://docs.google.com/forms/d/e/1FAIpQLSf0DKvaVcS3y11XkfseGL3WP344DT9Ms9I2RqogQRJcdMGfmw/viewform>

"Poets of Norwalk" Accounts

Designed to be a hub for posting events/announcements related to the poets and poetry events in Norwalk.

Poets of Norwalk

<https://linktr.ee/poetsofnorwalk>.

@poetsofnorwalk (Instagram)

poets.of.norwalk@gmail.com

4. Evelyn Cunningham, NPL Children's Librarian, Won the Connecticut Library Association's (CLA) Faith Hektoen Award

Ms. Harris announced that Ms. Cunningham, Children's Librarian at the Norwalk Public Library, has received the Faith Hektoen Award. She shared a brief biography, noting that the full press release was created and sent to media.

Ms. Brescia suggested that the Board send a letter of congratulations, and the Board unanimously agreed.

5. FY2025-26 Recommended Operating Budget
[FY 2025-26 Recommended Operating Budget - Final](#)
Library/Starting on page 183 of 306

Ms. Harris provided an update on the operating budget, noting that there have been no changes. She confirmed that the two current funding requests—one for landscaping and the other for books—have been approved. The book request includes \$15,000 to support e-books and digital downloads. She added that in the upcoming fiscal year, they plan to request \$60,000 to accommodate the growing population in Norwalk.

6. Approved FY 2025-26 Capital Budget and Capital Existing Project Updates
<https://www.norwalkct.gov/DocumentCenter/View/35927/FY-2025-26-Approved-Capital-Budget>

Ms. Harris reviewed the items approved through the Capital Budget and provided an update on their progress. She noted the increasing use of electric vehicles and expressed confidence in their preparedness, citing the availability of a charger at the main library and upcoming installation at the SoNo Library. She mentioned that funding was approved in the Capital Budget for a new electric van and sought the Board's input on transitioning to electric vehicles instead of gas-powered ones. The Board agreed that electric vehicles are a more practical choice.

Ms. Brescia added that the vehicles are expected to remain in use for over 10 years and emphasized the importance of making forward-thinking decisions.

Ms. Harris also reported on upcoming capital projects, including roof replacements at both library locations and the elevator cap replacement.

7. Upcoming Programs

Ms. Harris announced an upcoming session with holistic healer Antje Bakalov, scheduled for May 15.

She also highlighted that James Walker—a podcaster and former City Editor at The Hour and Senior Editor at the New Haven Register—has authored a book titled *Dead Windows: My Long Journey Out of Domestic Violence*. He will speak at the library on Wednesday, May 14, from 12:00–1:00 p.m. and again from 6:30–7:30 p.m. His biography is included in the agenda packet.

VI. OLD BUSINESS

There was no old business to discuss.

VII. NEW BUSINESS

There was no new business to discuss.

VIII. ADJOURNMENT

- ** MS. BRESCIA MOVED TO ADJOURN THE MEETING**
- ** MR. KNOPP SECONDED THE MOTION.**
- ** THE MOTION PASSED UNANIMOUSLY.**

The meeting was adjourned at 7:48 p.m.

Respectfully submitted
China Mayhew
Telesco Secretarial Services

BOARD REPORT

Sherelle Harris, Library Director
June 9, 2025



The Norwalk Public Library System, with our open access to diverse resources, is the information and cultural center for Norwalk citizens and businesses.





TO: Norwalk Public Library Board of Directors
FROM: Sherelle Harris, Library Director
DATE: June 9, 2025
RE: Main Library Parking Lots Update

Main Library Parking Lots Meeting & Discussion

August 13, 2024

(Revised May 3, 2025. June 7, 2025)

Norwalk Parking Authority: Sirak Legesse, Bryan Lutz

Norwalk Public Library: Sherelle Harris, Moina Noor, Jannie Williams

Norwalk Public Library (NPL) and Norwalk Parking Authority walked the exterior of the Main Library for the purpose of making library parking more cohesive for visitors with clear signage and easy accessibility to the library from each lot. NPL currently has three (3) lots. NPL's lot that is directly adjacent to the west side of the library off of Mott Avenue has 37 spaces, one of which houses a storage container and two of which are handicap accessible. West of NPL's lot is the Eagles Club (6 Mott Avenue) parking lot. [The city initially used the library's grounds account to rent 30 of those spaces](#) for library parking; however for FY 2025-2026, the city will use the library ground's account to rent 17 of those spaces for a lesser amount. The other 13 spaces will be used for the Wall Street Corridor Improvement Project staging materials. Next door to the library's north entrance is the 3 Belden Avenue parcel, [acquired recently by the City](#) of Norwalk. [11 of those parking spaces are reserved for library visitors.](#) See also the [acquisition of 11 Belden Avenue.](#)

Main Library Parking Spaces

Library Lot	Mott Avenue	37 spaces
3 Belden Lot	Belden Avenue	11 spaces
Eagles Lot	Mott Avenue	30 spaces at present

Please note that Dick Brescia secured approximately 15 spaces in the Yankee Doodle Garage for library parking when he was chair of the Norwalk Parking Authority.

UPDATE: May 19 email sent to Herb Sanford from Lamond Daniels, Community Services Chief.

In reviewing this matter with Corporation Counsel this week, it has come to my attention that the City has a right to extend the lease for a period of one (1) year at the current rate of \$12,500 for the year. Here's the advice I received from our counsel.

From City Attorney: "Lamond, Eagle's right to renegotiate rent at the end of the Initial Term expired on January 31, 2025. Per the terms of the Lease (copy attached for your ease of reference), Section 4.2 states that "The Landlord may initiate renegotiation of Rent applicable the Renewal Term (the "Adjusted Rent") by providing **written notice** thereof to the Tenant . . . **no less than one hundred and fifty (150) prior to the expiration of the Initial Term.** Said notice shall state the Adjusted Rent. . ." This provision is in the agreement so that the City would receive notice in advance of its fiscal budget process and plan accordingly. I did not receive written notice to renegotiate from Eagles in accordance with Section 17.2 of the Agreement. The time to give that notice has expired. We have a contractual right to extend the term at the current rent rate."

LEASE

3. Rent. The annual total rent hereunder shall be **TWELVE THOUSAND SIX HUNDRED DOLLARS AND 00/100 CENTS (\$12,600.00)** (the "Rent"), payable in equal monthly installments of One Thousand Fifty Dollars and 00/100 Cents (\$1,050.00) on or before the first day of each month commencing on the Commencement Date. The "Commencement Date" shall mean July 1, 2023, the date which the Tenant may commence occupying the

Striping NPL's parking lot off of Mott Avenue

We revisited a previous discussion on May 23, 2024 about striping the parking lot for a better visibility and adding signage at the parking lot's exit alerting that there is additional parking in the Eagle's lot. We discussed all day and overnight parkers. **Bryan and Sirak suggested a three (3)-hour parking limit to prevent all day and overnight parking.** Supervisors suggested 4-hour parking, instead, for patrons who attend programs and then want to use the library. The Library Board's opinion is that parking spaces are tight and suggested wider spacing between the lines.

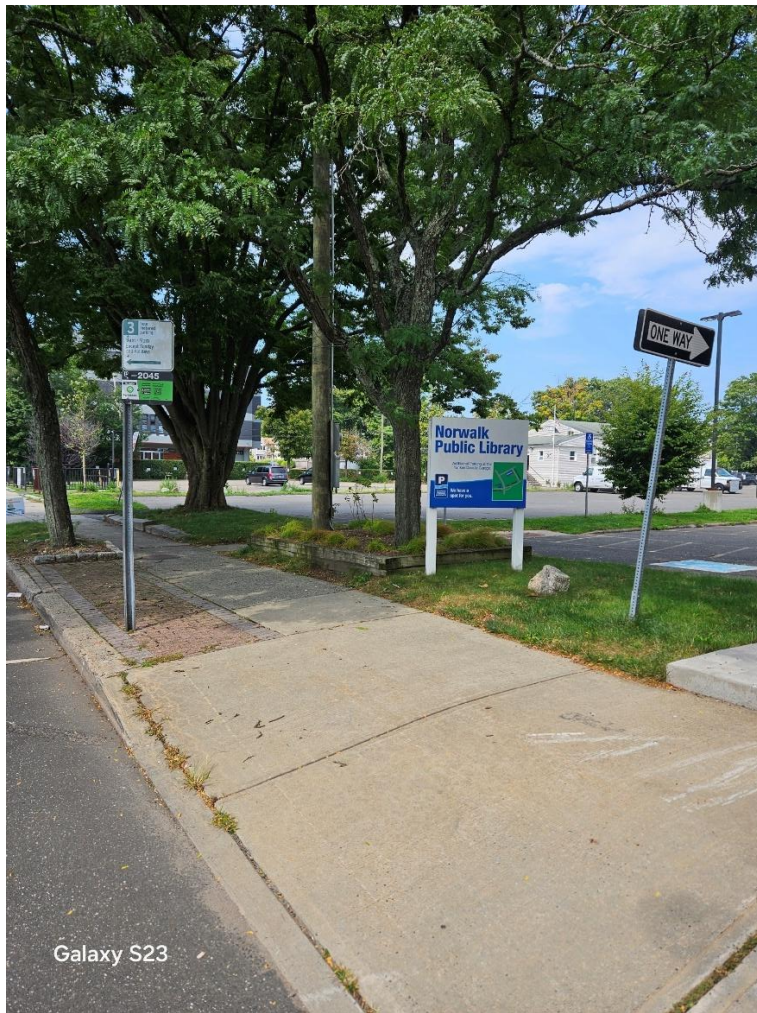

Sign, left, instructs drivers how to pay for on-street parking

While parking will remain free, the lot will be monitored by the Parking Authority monitors on-street parking and violators of the specified parking limit will receive tickets. This will help with parking turnover, so more people get a chance to park in the lot and use the library.



Library parking exit at Mott Avenue

Requested actions:

- 1) Stripe NPL's parking lot for better visibility of parking lines, **widen spaces.**
- 2) Make the exit arrows on the pavement more visible.
- 3) Add signage at the exit alerting to additional parking in the adjacent Eagle's lot.
- 4) Inquire as to whose responsibility it is and/or get an estimate for this cost of the work.

NOTE: The Parking Authority has taken this responsibility.

Reversing NPL's parking lot entrance and exit

~~We discussed changing NPL's entrance and exit for the purposes of placing our exterior book drop closer to the library. The book drop allows patrons to deposit their library books from the driver's side of the car without exiting the car. Reversing the two would also have drivers go down the slight decline rather than up the slight incline. **The recommendation is not to reverse the entrance and exit due to a blind spot which causes concern for liability and safety.**~~

Accessibility Parking

We also revisited the topic of on-street handicap/accessibility parking. At present, the two handicap spaces the library presently has are in the parking lot and they are not near either entrance.



Current handicap spaces in the NPL lot. These two spaces are located just to the left of the lot's entrance, across from the sidewalk leading to the Mott Avenue entrance.



Eight (8) street spaces 30-minutes free





There are eight (8) free, 30-minute on-street parking spaces in front of NPL's Mott Avenue entrance. We discussed making two of those spaces accessibility parking. Dilemma: The Parking Authority can manage paid, accessibility parking, but they are unsure as how to unpaid accessibility parking will work. (Bryan and Sirak discussed having standardize on-street parking, a regulation change that will have SoNo match Wall Street). **This is a great idea for ease, but considered dangerous to have patrons with accessibility parking needs to exit their cars in the traffic on this relatively busy street.**

In addition to discussing the possibility of having on-street accessibility parking in front of the Library's Mott Avenue entrance, we discussed moving the two handicap/accessibility spaces from the south side of the parking lot to the north side because accessibility to the sidewalk is flatter and less prohibitive.

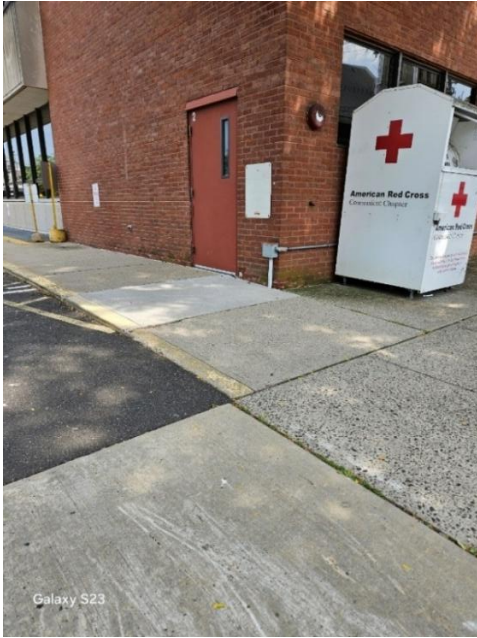

Directly across from the two current accessibility spaces.

This area has a curb.



Directly across from the area proposed to move the accessible spaces for easier access to the north entrance.

We will discuss with Bull Hnatuk, City of Norwalk's ADA Coordinator.

We will forgo the thought of having accessibility parking on the street in front of the library entrance due to the dangers posed. If we decide against moving the current handicap/accessibility spaces to the opposite end of the lot, we would like to have leveled the area where the two spaces are at present

Requested actions:

- 1) Level the ground where the current two handicap parking spaces are in the library parking lot.**
- 2) Consider if we should have four (4) handicap spots, two (2) on both ends of the parking lot.**

Eagle's Lot

NPL leases 30 spaces in the Eagle's parking lot. Those spaces are directly adjacent to the west side of NPL's lot, but they are neither noticeable nor identified as library parking.

Norwalk Public Library's leased spaces in the Eagle's parking lot



Requested action: The-17 spaces leased from Eagle's should be identified with signage. Herb Sanford, Eagles Treasurer, said he is fine with the signage. He likes the wording used to identify library parking in the 3 Belden Avenue lot.



3 Belden Avenue Parking Lot

There are 11 spaces reserved for NPL visitors in the 3 Belden Avenue parking lot. These spaces are closest to the M&T Bank. The other spaces, the spaces closest to the 3 Belden Avenue building are for those utilizing the space and their visitors. An island divides the two. Cars enter on the side where the 3 Belden Avenue parking spaces are and exit on the side where the NPL spaces are. NPL spaces have signs identifying the spaces as for library visitors; however, there is neither directional signage nor signage from the street (Belden Avenue) indicating that parking for library visitors is in the lot.

There is also a leaning pole at the beginning of the island that looks hazardous and unsightly.



East side of the 3 Belden Avenue, nearest the street



3 Belden Avenue parking on the left. Library visitor parking on the right.

Photo of car going out the wrong way in the 3 Belden Avenue parking lot, April 2025. Many cars also go in the wrong way causing near collisions with those trying to exit both the parking lot and the M&T drive through window.





The fence the library's north entrance and 3 Belden Avenue parking lot.

- Requested actions:**
- 1) Trim hedges on the east side of 3 Belden Avenue, near the sidewalk/street.
 - 2) Clean up the growth along the fence.
 - 3) Add directional in/out and **one-way** signage.
 - 4) Add signage alerting to library parking that can be seen from Belden Ave.
 - 5) Remove the tilting pole at the beginning of the island separating library and 3 Belden parking spaces.
 - 6) Remove the fence between the library and the 3 Belden Avenue parking lot and fix the egress issue for easier accessibility from the 3 Belden Avenue parking lot to the library.

END

UPDATE 4.1.25

Sign Proofs



ARTWORK PROOF SHEET

PLEASE CAREFULLY PROOF READ YOUR COPY

Check for spelling, punctuation, dimensions, colors, material and quantity.
Each additional revision after the allowed 2 will be charged
in 15 min increments at the price of \$25.00 Please allow an additional
day for each requested revision to the proof.

Production on project will not begin until approval is received.

NOTE: The colors you see on a monitor or paper proof are simply a representation of the colors. The actual colors will be determined by any PMS colors provided, which will be matched as close as possible on the actual printed product.
Please notify FASTSIGNS if you need to specifically see or select the color representation for your product.
Exact matches are not guaranteed.

Once a proof is approved, any mistakes in color, content or accuracy will be the responsibility of the custom

To Approve or Request Changes,
please visit your customer portal or email us at 636@fastsigns.com.

Thank you for your cooperation
All orders are custom, they are non-refundable and non-returnable.

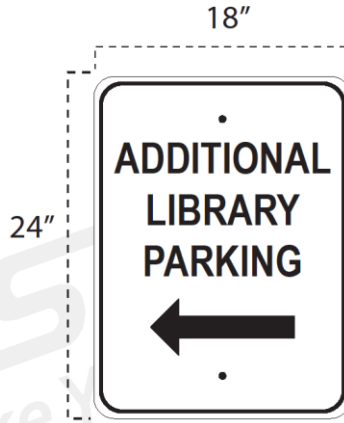

(QTY 1)

Aluminum .080 Sign (Non-Reflective)



ARTWORK PROOF SHEET

PLEASE CAREFULLY PROOF READ YOUR COPY

Check for spelling, punctuation, dimensions, colors, material and quantity.
Each additional revision after the allowed 2 will be charged
in 15 min increments at the price of \$25.00 Please allow an additional
day for each requested revision to the proof.

Production on project will not begin until approval is received.

NOTE: The colors you see on a monitor or paper proof are simply a representation of the colors. The actual colors will be determined by any PMS colors provided, which will be matched as close as possible on the actual printed product.
Please notify FASTSIGNS if you need to specifically see or select the color representation for your product.
Exact matches are not guaranteed.

Once a proof is approved, any mistakes in color, content or accuracy will be the responsibility of the custom

To Approve or Request Changes,
please visit your customer portal or email us at 636@fastsigns.com.

Thank you for your cooperation
All orders are custom, they are non-refundable and non-returnable.

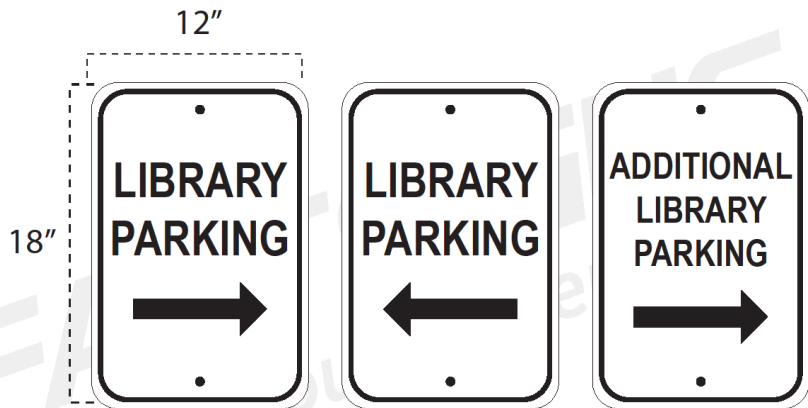

(QTY 2)

(QTY 2)

(QTY 1)

Aluminum .080 Signs (Non-Reflective)



583 Pacific St
Stamford, CT 06902
(203) 348-0222

INVOICE

I636-20430

Make Your Statement
fastsigns.com/636

Payment Terms: Net 30

Created Date: 4/1/2025

DESCRIPTION: Library Parking Signs

Bill To: LAZ Parking - Norwalk Parking Authority
Norwalk Public Library
One Belden Avenue
Norwalk, CT 06850
US

Pickup At: FASTSIGNS Stamford
583 Pacific St
Stamford, CT 06902
US

Ordered By: Sherelle Harris
Email: sharris@norwalkpl.org
Work Phone: (203) 970-1975
Cell Phone: (203) 970-1975
Tax ID: 06-6011881

Entered By: Danny Sancho

NO.	Product Summary	QTY	UNIT PRICE	TAXABLE	AMOUNT
1	Library Parking 12" x 18" (5) SS Library parking 12" by 18" (2) with left arrow (2) with right arrow (1) Additional parking with right arrow	5	\$77.952	\$0.00	\$389.76
1.1	Aluminum 080 Blank - 12x18 - with print and lam -				
2	Additional Library Parking 18"x24" (1) SS One 18" by 24" *left arrow*	1	\$180.60	\$0.00	\$180.60
2.1.1	Aluminum .080 - Substrate				
2.2.1	Laminate - Matte - Laminate				
3	Artwork/ Design / Setup Pre-press setup fee required for editing or creating production files for printing and fabrication. If you have questions about what type of artwork we need Click Here for Artwork Requirements Click Here for Good vs Poor Artwork Examples Any design time required will be added to the final invoice at an hourly rate of \$85.00/hr.	1	\$46.00	\$0.00	\$46.00
3.1	Graphic Design Fee -				

Subtotal:	\$616.36
Taxable Amount:	\$0.00
Taxes:	\$0.00
Grand Total:	\$616.36
Amount Paid:	\$0.00
DEPOSIT REQUIRED:	\$616.36

Balance payment is DUE before pickup/delivery/shipping/installation.

UPDATE 5.1.25

Directional parking signs were added to the 1 Belden lot.



I asked that a library parking sign be placed on the Eagle's lot fence so when library see the "additional library parking" sign as they exit the library lot, they will know where the additional parking is.



UPDATE 5.3.25

1 Belden parking lot (Mott Avenue) has been restriped and the directional arrows were repainted.



The 3 Belden Avenue lot was also restriped.



UPDATE 6.2.25

Leaning pole on page 9 removed.



Hedges on page 9 trimmed. I suggest trimming them down more so that people, particularly, shorter people, can be seen by drivers from the parking lot before they get to the exit.



Please see the quote for fence removal overgrowth and shrubs. Neil is also seeking a proposal to fix the egress issue. NOTE: Money was rolled over from FYE 2023-24 to FYE 2024-25 to take care of this issue.



Builder • Developer • Contractor
540 Main Street, Ansonia, CT. 06401
PH: 203.395.1692



TitanEnterprisesInc@yahoo.com

Proposal 25395

May 20, 2025

Neil Rennie
City of Norwalk Public Library
1 Belden Ave.
Norwalk, CT 06850

Re: Norwalk City Public Library.

Scope of Work:

All work proposed is for the exterior work at the above referenced address. All work to be performed in accordance with state and local building codes.

Remove and replace approximately 40' of 4' chain link fence to match existing at property line between parking lot and library. Clean up overgrowth vegetation, shrubs and logs. Remove 3" of topsoil. Install new crushed stone over filter fabric. Also install +/-4' wide x +/-5' long x 4" thick concrete walk from parking lot to library sidewalk.

\$ 8,800.

*This proposal may be withdrawn by Titan Enterprises if not accepted within 30 days.

*All work in the above will be fully covered by the workman's compensation, and general liability. All work is to be completed in a workman like manner accordance with specifications submitted for above work and standard practices.

*Any Alterations or deviation from above specifications involving extra cost will be executed only upon written order and will become an extra charge over and above the estimate.

Respectfully submitted,

Anthony Esposito
Titan Enterprises Inc.

TO DO LIST 6.9.25

The library parking sign for Eagles' fence is ready for pick up.



A brief discussion with Jim Travers took place on May 27, 2025 about the Parking Authority taking over the library parking lots again. Email follow ups were sent to Jim Travers, Bryan Lutz and Sirak Legesse on May 28, 2025. Follow-up email sent on June 9, 2025

I proposed having Laz/Norwalk Parking Authority monitor library lots, which will remain free of charge for the allotted three or four hours, and giving tickets to those who overstay their allotted time. Three hours is consistent with the limit the parking authority set forth for the rest of the city. They can charge visitors who stay longer.

Directional in/out signage needed for the 3 Belden Avenue parking lot.

The fence removal and egress issues have not been taken completed yet; however, Guardian, Norwalk's building management company, has received a quote to clean shrubs and overgrowth in addition to removing the fence. Neil/Guardian is currently working on quotes for the remaining egress work.

CAPITAL PROJECT UPDATES

City of Norwalk and NPS / Board of Ed					*FINAL*
Final Approved FYE 2026 Capital Budget					
04/14/25 -- Version 8					FYE 2026
printed: 4/25/2025 10:10					Common Council
Division	SubDivision	Rank	ProjectName	Proj ID	Approved 4/8/25
FINANCE DEPT	INFORMATION TECH	1	INFORMATION TECHNOLOGY PROJECTS	C0375	625,000
	INFORMATION TECH Total				625,000
FINANCE DEPT Total					625,000
COMMUNITY SVCS	CHIEF OF COMM SERVICES	1	ADA COMPLIANCE	C0536	450,000
	CHIEF OF COMM SERVICES Total				450,000
COMMUNITY SVCS	LIBRARY ADMIN	1	MAIN LIBRARY ADA DOOR HANDLES	C0692	31,500
COMMUNITY SVCS	LIBRARY ADMIN	2	LIBRARY VAN	NEW	84,113
COMMUNITY SVCS	LIBRARY ADMIN	3	NORWALK NEWSPAPER DIGITIZATION	C0548	23,148
COMMUNITY SVCS	LIBRARY ADMIN	4	LAPTOP VENDING MACHINES	NEW	17,000
	LIBRARY ADMIN Total				155,761
COMMUNITY SVCS Total					605,761

City of Norwalk and NPS / Board of Ed					EXHIBIT A	*FINAL*
Final Approved FYE 2025 Capital Budget						
04/11/24 -- Version 8						FYE 2025
printed: 4/15/2024 16:32						Council
Division	SubDivision	Rank	ProjectName	Proj ID	Approved 4/9/25	
FINANCE DEPT	INFORMATION TECH	1	INFORMATION TECHNOLOGY PROJECTS	C0375	1,000,000	
FINANCE DEPT Total						1,000,000
COMMUNITY SVCS	CHIEF OF COMM SERVICES	1	ADA COMPLIANCE	C0536	221,470	
COMMUNITY SVCS	HEALTH ADMINISTRATION	2	PAINTING	NEW	10,000	
COMMUNITY SVCS	HEALTH ADMINISTRATION	3	BUILDING RENOVATIONS	NEW	20,000	
COMMUNITY SVCS	LIBRARY ADMIN	1	MAIN LIBRARY ADA COMPLIANT DOOR HANDLES	NEW	16,000	
COMMUNITY SVCS	LIBRARY ADMIN	2	SONO LIBRARY ADA COMPLIANT PARKING LOT	NEW	46,362	
COMMUNITY SVCS	LIBRARY ADMIN	4	SONO LIBRARY SECURITY ALARM & INTERCOM	NEW	11,000	
COMMUNITY SVCS	LIBRARY ADMIN	5	SONO LIBRARY SECURITY CAMERAS	NEW	18,037	
COMMUNITY SVCS	LIBRARY ADMIN	6	MAIN LIBRARY SECURITY CAMERAS	NEW	18,037	
COMMUNITY SVCS	LIBRARY ADMIN	7	NORWALK NEWSPAPER DIGITIZATION	C0548	22,800	
COMMUNITY SVCS	LIBRARY ADMIN	8	TECHNOLOGY UPGRADES	C0828	23,700	
COMMUNITY SVCS Total						407,405

Gengras Ford, LLC

225 New Britain Avenue
 Plainville, CT 06062
 Phone: 860.727.6302
 www.gengras.com



Quote Number: **250410010.1**

STATE CONTRACT NO: 24PSX0110

Make	MY	Model	Contract Price
Ford	2025	Transit - 350 Cargo Van Low Roof (W1Y)	\$ 46,196.00

All specifications are subject to verification of manufacturer's published standard and optional equipment. Vehicle to include all manufacturers standard equipment plus the following options:

	Option Code	Description	List Price
1	W1X-148	Transit T-350 Cargo Van High Roof 148 WB Long Length RWD	\$ 1,000.00
2	YZ	Oxford White	\$ -
3	VK	Palazzo Gray	\$ -
4	99M	Electric Motor (E-Transit) with 89.9kWH High-Voltage Battery	\$ 1,400.00
5	44A	One Speed Transmission	\$ -
6	15F	Rear Compartment Light	\$ 70.00
7	21P	Driver and passenger two-way vinyl	\$ 45.00
8	545	Short-Arm Power Mirrors	\$ 150.00
9	STD	SYNC 4	\$ -
10	68H	Running Boards	\$ 290.00
11	86F	Fleet Keys (4 total)	\$ 70.00
12			\$ -
13			\$ -
14			\$ -
15			\$ -
16			\$ -
17			\$ -
18			\$ -
19			\$ -
20			\$ -
21			\$ -
22			\$ -
23			\$ -
24			\$ -
25			\$ -
<i>Total Options per Contract Price (list price)</i>			\$ 3,025.00
<i>Total Factory Options Discount (6%)</i>			\$ (181.50)
<i>Total Options per Contract Price (net price)</i>			\$ 2,843.50



Quote Number: **250410010.1**

Aftermarket Accessories				
	Vendor / Manufacturer	Hours	Description	List Price
1	Other	2.0	Install fixed perforated partition	\$ 1,652.00
2		0.0		\$ -
3		0.0		\$ -
4		0.0		\$ -
5		0.0		\$ -
Total Hours		2.0		
				Total Aftermarket Options (list price) \$ 1,652.00
				Total Aftermarket Options Mark-up (5%) \$ -
				Total Hours x \$110 / hour rate \$ 220.00
				Total Net Aftermarket Options plus Total Labor \$ 1,872.00
Trade Allowance				
Year	Make	VIN	Description / Mileage	Allowance
				\$ -
				\$ -
				\$ -
				Total Trade in Allowance \$ -
Comments:			Additional fees / Charges	
Budget price for discussion purposes only			State of CT Trade in Assessment (Note: Fee is payable to State of CT):	\$ -
			Dealer Conveyance Fee (\$799.00)	\$ -
			Registration Fee (estimated, actual cost will appear on your final invoice)	\$ -
			DMV Inspection Fee (as required)	\$ -
			Total Additional Fees	\$ -
Customer:	City of Norwalk		Total (per unit)	\$ 50,911.50
FIN Code:	QQ243			
VIN:			Grand Total (all)	\$ 50,911.50
Quantity	1			

This quote valid for 30 days from the date created

We have money left over to pay to put the logo on the van.

New York State
License # 12000042719

Connecticut State
License # 105911

New Jersey
License # 34BA00174700

Security Specialists

Div. of ALERT SYSTEMS, LLC.
3 Depinedo Ave - Stamford, CT 06902
Phone: 800-753-8400



STANDARD SYSTEM SALES AGREEMENT

Date:	4/4/2025
Quote #:	AAAQ8568
P.O #:	
Rep:	Kimberly

Sold To: Norwalk Library
Sherelle Harris
1 Belden Ave
Norwalk, CT 06850

Ship To: Norwalk Library
Sherelle Harris
1 Belden Ave
Norwalk, CT 06850

Phone: 203-899-2780

Phone: 203-899-2780

Scope of work

Security Specialists is pleased to quote the following:

Install 12 terabyte ExacqVision Video Surveillance 2U Server in the server rack in basement of main library. This recorder has expansion capabilities in the event camera additions arise in the future. 30 days storage based on current load.

Install exterior cameras as follows:

- 1 Dual Head Camera covering main entrance and courtyard.
- 1 Dual Head Camera covering the parking lot and side of building (corner mount)
- 1 3 Headed Camera covering far side of building the entire walk waly and side entry.
- 1 -6 megapixel camera covering 2nd floor hall above door aiming out down hall towards stair entry and common area.

City of Norwalk is responsible for supplying 4 open ports on their network/POE switch and providing the IP's along with the vpn for the viewing client tie in at Norwalk PD dispatch if wanted. Install on up to 2 pc's with viewing client at library to be coordinated in advance (with Sherelle Harris), Sharelle to determine the other pc to install viewing software.

- 1 Wisenet 7 X-plus series network IR vandal indoor camera, 6MP @ 30fps, motorized vari-focal lens 3x (2.8-8.4mm), triple codec H.265/H.264/MJPEG with
- 1 Tilted wall mount for X series
- 1 Multisensor 3 head camera (3x2MP)
- 1 Cap Adapter
- 1 Camera Arm
- 3 Wall mount camera back box
- 2 Accessory, Wall Mount, Ivory
- 3 Corner mount kit
- 2 Dualhead camera (3MP x 2)
- 2 Dual Head Cap

Catagory 5E cable

IP 2U Rackmount A-Series exacqVision NVR with 8 IP Professional licenses (64 max), 12TB Internal JBOD storage. Windows 10 IoT Ent LTSC OS on SSD, 8GB RAM, Dual 2.5GbE on-board, 4 x USB, 1 x HDMI, 2 x DP, 1 x VGA. Includes rackmount sliding rail kit, mouse and keyboard

Installation

Program & Training

04/04/25

1

Misc. Hardware & shipping

SubTotal	\$18,368.82
Sales Tax	\$0.00
Shipping	\$0.00
Total	\$18,368.82
Deposit:	\$0.00
Balance	\$18,368.82

FINAL BALANCE DUE IN FULL UPON COMPLETION OF INSTALLATION AND SYSTEM ACTIVATION

NOTICE OF CANCELLATION

You, the Buyer, may cancel this contract at any time prior to midnight of the third business day of this transaction. See attached notice of cancellation form for an explanation of this right. (Residential customers only)

Sales Rep: _____
Signature

Buyer: _____
Signature

Sales Rep: _____
Print Full Name

Buyer: _____
Print Full Name

Date: _____

TERMS, CONDITIONS AND LIMITED WARRANTY

- 1- In the event that any part of the system becomes defective, or in the event that any repairs are required, Seller agrees to make all repairs and replacement of parts without cost to the Buyer for a period of one (1) year from the date of installation. Seller reserves the option to either replace or repair the equipment, and reserves the right to substitute materials of equal quality at time of replacement, or to use reconditioned parts in fulfillment of this warranty. This warranty does not include batteries, reprogramming, damage by lightning or electrical surge.
- 2- Except as set forth in this agreement, Seller makes no express warranties as to any matter whatsoever, including, without limitation, the condition of the equipment, its merchantability, or its fitness for any particular purpose. Seller does not represent nor warrant that the system may not be compromised or circumvented; or that the system will prevent any loss. Seller expressly disclaims any implied warranties, including implied warranties of merchantability or fitness for a particular purpose.
- 3- This warranty does not cover any damage to material or equipment caused by accident, misuse, attempted or unauthorized repair service, modification, or improper installation by anyone other than Seller. Seller shall not be liable for consequential damages. Buyer acknowledges that any affirmation of fact or promise made by Seller shall not be deemed to create an express warranty unless included in this contract in writing; that Buyer is not relying on Seller's skill or judgment in selecting or furnishing a system suitable for any particular purpose and that there are no warranties which extend beyond those on the face of this agreement.
- 4- Buyer's exclusive remedy for Seller's breach of this contract or negligence to any degree under this contract is to require Seller to repair or replace, at Seller's option, any equipment or part of the system which is non-operational.
- 5- This warranty gives you specific legal rights and you may also have other rights which vary from state to state. If required by law, Seller will procure all permits required by local law with regard to the physical installation process. Seller will provide a certificate of insurance prior to starting work if requested to do so by the Buyer in writing.
- 6- Seller makes no representation that network connectivity for remote viewing, administration or other functionality can be provided. Network connectivity, network configuration, firewall configuration and internet service shall be provided by and at the expense of the buyer. If buyer requests that seller perform network or firewall configuration the buyer shall pay the seller for such service at the seller's prevailing time and material rates for such service even in the event that remote functionality is not accomplished.
- 7- DELAY IN INSTALLATION: Seller shall not be liable for any damage or loss sustained by Buyer as a result of delay in installation of equipment, equipment failure, or interruption of service due to electric failure, strikes, walk-outs, war, acts of God, or other causes, including Seller's negligence in the performance of this contract. The estimated date work is to be substantially completed is not a definite date and time is not of the essence.
- 8- ALTERATION OF PREMISES FOR INSTALLATION: Seller is authorized to make preparations such as drilling holes, driving nails, making attachments or doing any other thing necessary in Seller's sole discretion for the installation and service of the system, and Seller shall not be responsible for any condition created thereby as a result of such installation, service, or removal of the system, and Buyer represents that the owner of the premises, if other than Buyer, authorizes the installation of the system under the terms of this agreement.
- 9- BUYER'S DUTY TO SUPPLY ELECTRIC, INTERNET AND TELEPHONE SERVICE: Buyer agrees to furnish, at Buyer's expense, all 110 Volt AC power and electrical outlets and receptacles, telephone hook-up, RJ31 Block or equivalent and network drops, as deemed necessary by Seller.
- 10- BUYER'S RESPONSIBILITIES: Buyer is solely responsible for any permit fees and any other municipal assessments related to the equipment and shall promptly on demand reimburse and indemnify Seller for any such expense.
- 11- BUYER'S FAILURE TO PAY: In the event Buyer fails to pay Seller any monies when due, Buyer shall pay interest at the rate of 1 1/2% per month from the date when payment is due.
- 12- LIEN LAW: Seller or any subcontractor engaged by Seller to perform the work or furnish material who is not paid may have a claim against Buyer or the owner of the premises if other than the Buyer which may be enforced against the property in accordance with the applicable lien laws.
- 13- SELLER'S RIGHT TO SUBCONTRACT SPECIAL SERVICES: Buyer agrees that Seller is authorized and permitted to subcontract special services which Seller is obligated to perform under this contract, and that Seller shall not be liable for any loss or damage sustained by Buyer by any cause whatsoever caused by the negligence of third parties.
- 14- LEGAL ACTION: Any action by Buyer against Seller must be commenced within one year of the accrual of the cause of action or shall be barred. All actions or proceedings against Seller must be based on the provisions of this agreement. Any other action that Buyer may have or bring against Seller in respect to other services rendered in connection with this agreement shall be restricted to the terms and conditions of this agreement.
- 15- FULL AGREEMENT/SEVERABILITY: This agreement constitutes the full understanding of the parties; there are no verbal agreements or representations and Buyer has relied on none. This agreement cannot be modified except in writing signed by the parties hereto. Should any provision of this agreement be deemed void, the remaining parts shall not be affected.

New York State
License # 12000042719

Connecticut State
License # 105911

New Jersey
License # 34BA00174700

Security Specialists

Div. of ALERT SYSTEMS, LLC.

3 Depinedo Ave - Stamford, CT 06902

Phone: 800-753-8400



STANDARD SYSTEM SALES AGREEMENT

Date:	4/4/2025
Quote #:	AAAQ8569
P.O #:	
Rep:	Kimberly

Sold To: Norwalk Library
Sherelle Harris
1 Belden Ave
Norwalk, CT 06850

Phone: 203-899-2780

Ship To: Norwalk Library-SONO Branch
Sherelle Harris
10 Washington St
Norwalk, CT 06850

Phone: 203-899-2780

Scope of work

Security Specialists is pleased to quote the following:

Install 8 terabyte ExacqVision Video Surveillance 2U Server in the server rack in ground floor utility room of sono library. This recorder has expansion capabilities in the event camera additions arise in the future. 30 days storage based on current load.

Install exterior cameras as follows:

1 Dual Head Camera covering main entrance and parking area

1 Dual Head Camera covering the basementa door and side lawn of building (corner mount)

City to confirm we are able to use the sidewalk light pole for camera mounting as to not disrupt the facet of front of building with lime stone. Put Trend net point to point with POE injector and mount camera to pole to cover front side of library.

NVR should be placed in the ground floor mechanical room where switch resides.

City of Norwalk is responsible for supplying 3 open ports on their network/POE switch and providing the IP's along with the vpn for the viewing client tie in at Norwalk PD dispatch if wanted. Install on up to 2 pc's with viewing client at library to be coordinated in advance (with Sherelle Harris), Sharelle to determine the other pc to install viewing software.

- 2 Wall mount camera back box
- 2 Accessory, Wall Mount, Ivory
- 2 Corner mount kit
- 2 Dualhead camera (3MP x 2)
- 2 Dual Head Cap
- 1 Vandal Dome Pendant Cap
- 1 5MP Vandal Dome w/ Extender
- 1 Trendnet Point to Point Wireless Link
- 1 pole mount for xrv
- 1 Cap for XNV
- 1 PoE Injector

Catagory 5E cable

IP 2U Rackmount A-Series exacqVision NVR with 8 IP Professional licenses (64 max), 12TB Internal JBOD storage. Windows 10 IoT Ent LTSC OS on SSD, 8GB RAM, Dual 2.5GbE on-board, 4 x USB, 1 x HDMI, 2 x DP, 1 x VGA. Includes rackmount sliding rail kit, mouse and keyboard
Installation

04/04/25

1

Program & Training
Misc. Hardware & shipping

SubTotal	\$16,078.95
Sales Tax	\$0.00
Shipping	\$0.00
Total	\$16,078.95
Deposit:	\$0.00
Balance	\$16,078.95

FINAL BALANCE DUE IN FULL UPON COMPLETION OF INSTALLATION AND SYSTEM ACTIVATION

NOTICE OF CANCELLATION

You, the Buyer, may cancel this contract at any time prior to midnight of the third business day of this transaction. See attached notice of cancellation form for an explanation of this right. (Residential customers only)

Sales Rep: _____
Signature

Buyer: _____
Signature

Sales Rep: _____
Print Full Name

Buyer: _____
Print Full Name

Date: _____

TERMS, CONDITIONS AND LIMITED WARRANTY

1- In the event that any part of the system becomes defective, or in the event that any repairs are required, Seller agrees to make all repairs and replacement of parts without cost to the Buyer for a period of one (1) year from the date of installation. Seller reserves the option to either replace or repair the equipment, and reserves the right to substitute materials of equal quality at time of replacement, or to use reconditioned parts in fulfillment of this warranty. This warranty does not include batteries, reprogramming, damage by lightning or electrical surge.

2- Except as set forth in this agreement, Seller makes no express warranties as to any matter whatsoever, including, without limitation, the condition of the equipment, its merchantability, or its fitness for any particular purpose. Seller does not represent nor warrant that the system may not be compromised or circumvented; or that the system will prevent any loss. Seller expressly disclaims any implied warranties, including implied warranties of merchantability or fitness for a particular purpose.

3- This warranty does not cover any damage to material or equipment caused by accident, misuse, attempted or unauthorized repair service, modification, or improper installation by anyone other than Seller. Seller shall not be liable for consequential damages.

Buyer acknowledges that any affirmation of fact or promise made by Seller shall not be deemed to create an express warranty unless included in this contract in writing; that Buyer is not relying on Seller's skill or judgment in selecting or furnishing a system suitable for any particular purpose and that there are no warranties which extend beyond those on the face of this agreement.

4- Buyer's exclusive remedy for Seller's breach of this contract or negligence to any degree under this contract is to require Seller to repair or replace, at Seller's option, any equipment or part of the system which is non-operational.

5- This warranty gives you specific legal rights and you may also have other rights which vary from state to state. If required by law, Seller will procure all permits required by local law with regard to the physical installation process. Seller will provide a certificate of insurance prior to starting work if requested to do so by the Buyer in writing.

6- Seller makes no representation that network connectivity for remote viewing, administration or other functionality can be provided. Network connectivity, network configuration, firewall configuration and internet service shall be provided by and at the expense of the buyer. If buyer requests that seller perform network or firewall configuration the buyer shall pay the seller for such service at the seller's prevailing time and material rates for such service even in the event that remote functionality is not accomplished.

7- DELAY IN INSTALLATION: Seller shall not be liable for any damage or loss sustained by Buyer as a result of delay in installation of equipment, equipment failure, or interruption of service due to electric failure, strikes, walk-outs, war, acts of God, or other causes, including Seller's negligence in the performance of this contract. The estimated date work is to be substantially completed is not a definite date and time is not of the essence.

8- ALTERATION OF PREMISES FOR INSTALLATION: Seller is authorized to make preparations such as drilling holes, driving nails, making attachments or doing any other thing necessary in Seller's sole discretion for the installation and service of the system, and Seller shall not be responsible for any condition created thereby as a result of such installation, service, or removal of the system, and Buyer represents that the owner of the premises, if other than Buyer, authorizes the installation of the system under the terms of this agreement.

9- BUYER'S DUTY TO SUPPLY ELECTRIC, INTERNET AND TELEPHONE SERVICE: Buyer agrees to furnish, at Buyer's expense, all 110 Volt AC power and electrical outlets and receptacles, telephone hook-up, RJ31 Block or equivalent and network drops, as deemed necessary by Seller.

10- BUYER'S RESPONSIBILITIES: Buyer is solely responsible for any permit fees and any other municipal assessments related to the equipment and shall promptly on demand reimburse and indemnify Seller for any such expense.

11- BUYER'S FAILURE TO PAY: In the event Buyer fails to pay Seller any monies when due, Buyer shall pay interest at the rate of 1 1/2% per month from the date when payment is due.

12- LIEN LAW: Seller or any subcontractor engaged by Seller to perform the work or furnish material who is not paid may have a claim against Buyer or the owner of the premises if other than the Buyer which may be enforced against the property in accordance with the applicable lien laws.

13- SELLER'S RIGHT TO SUBCONTRACT SPECIAL SERVICES: Buyer agrees that Seller is authorized and permitted to subcontract special services which Seller is obligated to perform under this contract, and that Seller shall not be liable for any loss or damage sustained by Buyer by any cause whatsoever caused by the negligence of third parties.

14- LEGAL ACTION: Any action by Buyer against Seller must be commenced within one year of the accrual of the cause of action or shall be barred. All actions or proceedings against Seller must be based on the provisions of this agreement. Any other action that Buyer may have or bring against Seller in respect to other services rendered in connection with this agreement shall be restricted to the terms and conditions of this agreement.

15- FULL AGREEMENT/SEVERABILITY: This agreement constitutes the full understanding of the parties; there are no verbal agreements or representations and Buyer has relied on none. This agreement cannot be modified except in writing signed by the parties hereto. Should any provision of this agreement be deemed void, the remaining parts shall not be affected.

3

Init. _____

Main Library ADA-Compliant Door Handles \$31,500

Continue the successful maintenance of city-owned historic properties

The main library's interior and exterior door handles are not American Disabilities Act (ADA)-compliant. The building has traditional door handles found in homes that require a tighter grip and twisting wrist motions that cause us to be non-compliant with ADA regulations. We need lever style handles that meet ADA requirements. Neil Rennie, from Guardian and William Hnatuk, the city's ADA compliance coordinator, collaborated on this project.

Door Count: 60 interior and 3 exterior at \$500 per lockset (\$31,500)

NOTE: The second sliding door (at the north entrance) portion of this project was completed in March of 2025.



MAIN LIBRARY: 2025 POLLING LOCATION

District 137B (state years) | District A2 (municipal years)

September 9, 2025 Municipal Primary Election
(for Mayor, Common Council and Board of Education, etc.)

November 4, 2025 Municipal Election
(for Mayor, Common Council and Board of Education, etc.)

2024 TAX PROBONO RETURN STATISTICS

REPORT FROM MARK SPIVAK TAX PREPARER, SIMPLIFY CT

Between the two library locations we filed some 1,800 returns resulting in almost \$3 million in refunds.

This was about 15% less than the prior season, most likely due to the fact that we were shut out for two days one week due to a snowstorm. However, taken together, the libraries would be the third largest counseling site in Connecticut.

~END~

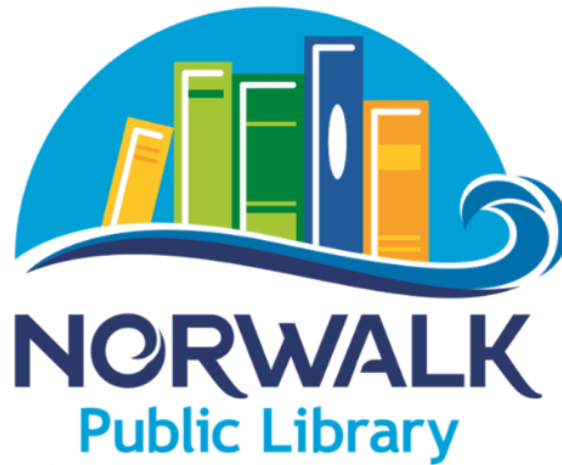

Main Branch - Furniture Images

June 5, 2025 - REVISED



Adult Area

Revised furniture drawing 4/28/25 from meeting notes.

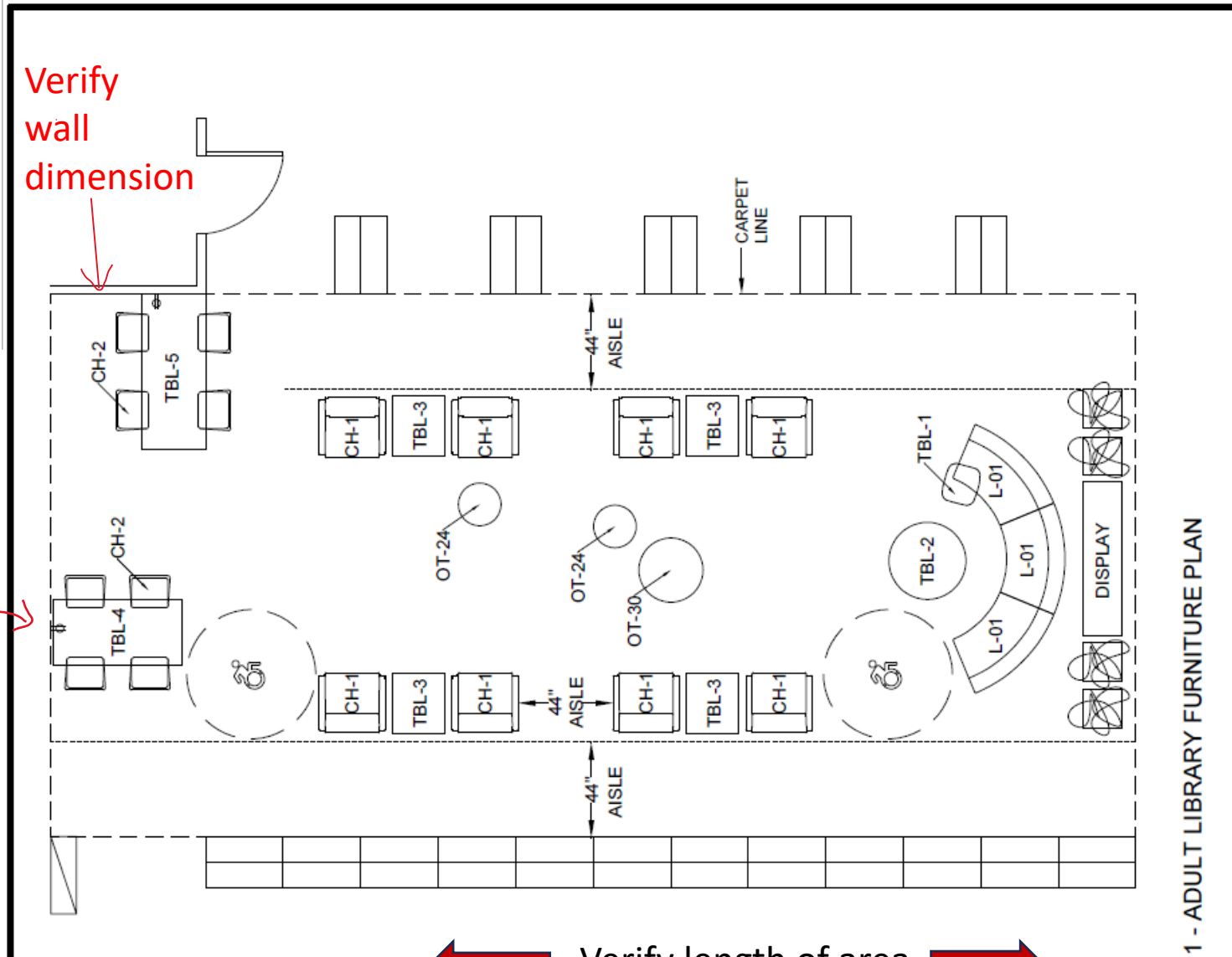

1 - ADULT LIBRARY FURNITURE PLAN



ROBERT H LORD CO.

220 Chapel Road
Manchester, CT 06042
P: (860) 645-8700
F: (860) 645-9100

**NORWALK
PUBLIC LIBRARY**

1 BELDEN AVE.
NORWALK, CT 06850

DRAWN: AK

SCALE: 3/16" = 1'-0"

REVISION: 2

DATE: 4/24/2025

**FURNITURE
PLAN**

Adult Area

3-D Colored Rendering

5.31.25 – some of the material colors shown on square tables and ottomans will need to be revised. Revisions will be added to slides when time permits.



Adult Area

3-D Colored Rendering



5.31.25 – some of the material colors shown on square tables and ottomans will need to be revised. Revisions will be added to slides when time permits.



Adult Area

3-D Colored Rendering

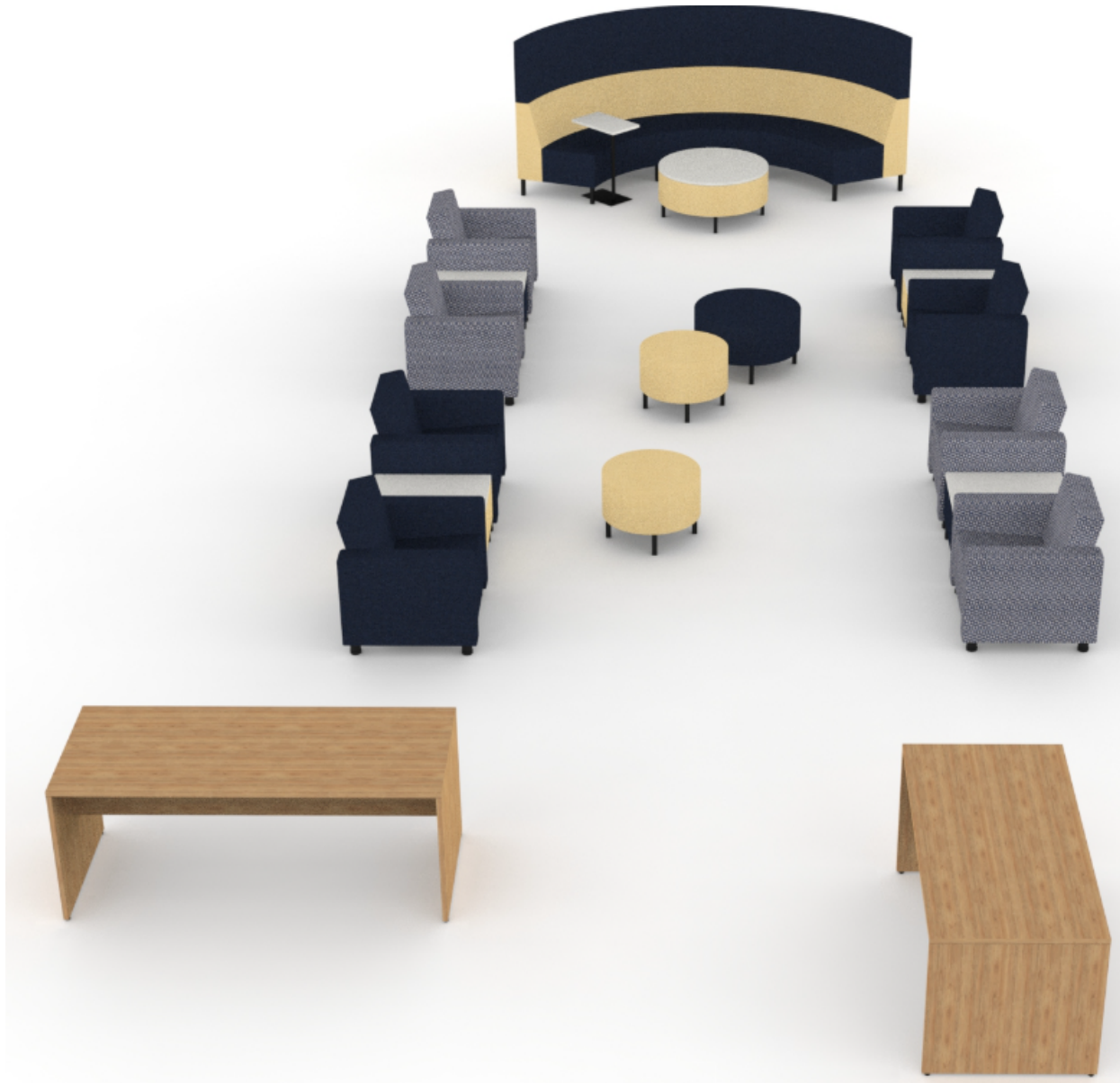

Adult Area

#L-01: Curved Lounge with wrapped tall back. OFGO Unify Series Modular Lounge. Segmented units to create the curves. Shown with 2-Tone materials. Made up of (3) 54”w x 28”d x 53”h. Black Metal Post Legs. Laminate top: Linea Mocha on ottoman.

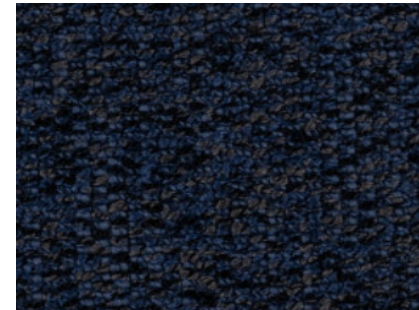

Seat and Top Back:
Mayer – Editor- Midnight
#WC920-024



Mid Center Back:
Stinson – Hopsack-Bamboo
#HOP-15

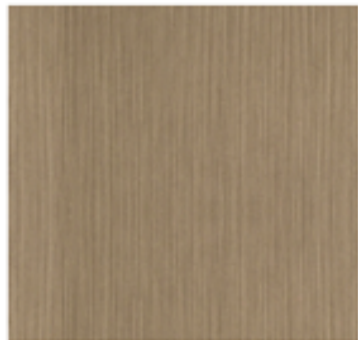

Linea Mocha (LM)

#CH-1 & #CH-1A: Lounge Chair - OFGO – Tribute Series Mobile Lounge Chair

Total Qty. (8) chairs: Single fabric. Black casters front and back on all chairs.



#CH-1: (4) Mayer – Ephesus – Indigo
#623-004

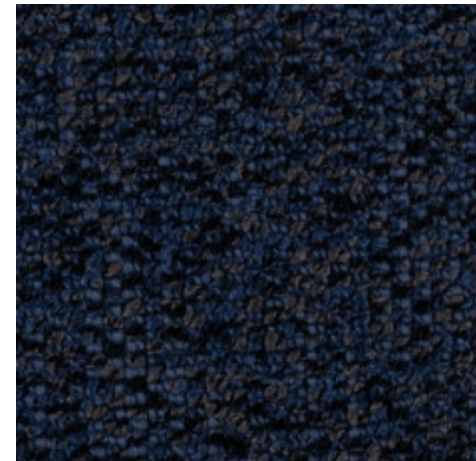

#CH-1A: (4) Mayer – Editor – Midnight
WC920-04

Adult Area

#TBL-1: Laptop Table – OFGO Studio - Pull Up Series Table.
20" w x 13" d x 27" h. TFL Laminate: Linea Mocha #LM.
Flat base slides easily under the Curved Benches and Lounge chairs. Metal post with flat base, Finish: Black. QTY: (2)



Laminate surface



Linea Mocha (LM)

Metal Finish

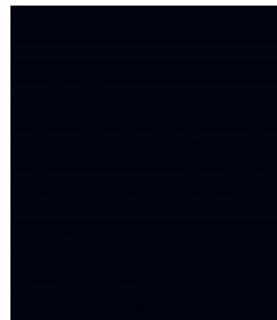

Black

Adult Area

#TBL-3A & TBL-3B : Occasional Table. OFGO – Unify Series.
24”w x 26”d x 18”h Laminate top with fabric sides.
Black Metal post legs. Fabric noted below.
Laminate top: Linea Mocha #LM



Linea Mocha (LM)

Laminate Top



(2) #TBL-3A

Fabric: Mayer, Editor:
Midnight - Grd. 10



(2) #TBL-3B

Fabric: Stinson,
Hopsack: Bamboo - Grd. 11



Adult Area

(1) #TBL-2: OFGO Studio - Unify Series 36" round ottoman with laminate top (table), fabric wrapped side Hopsack Bamboo. Laminate: Linea Mocha #LM. Legs: Black

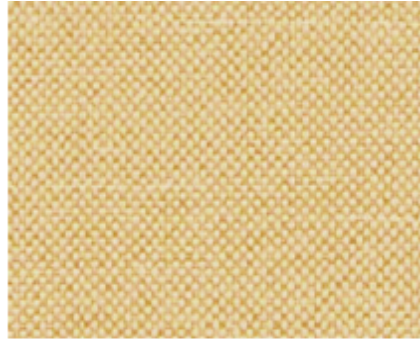

Stinson – Hopsack-
Bamboo, #HOP-15



Linea Mocha (LM)
Laminate top



(2) #OT-24: OFGO - Unify Series 24" round ottoman fabric side; Stinson Hopsack, Bamboo.

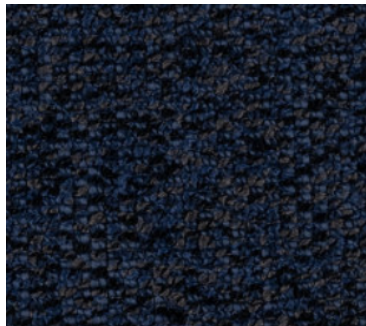

(2) #OT-30: OFGO – Unify Series 30" round ottoman fabric side; Mayer, Editor, Midnight. Qty. (1)

Adult Area

Tables: OFGO - Lets Meet Series Community (Collaborative) Tables

Panel Ends, modesty panel – wire management run down inside of one end panel. Includes OFGO #E3 Power unit Flush with surface top. 10 ft power cord – Plug in.

Center in table. Laminate: Color Linea Mocha. Power Box Finish: Silver Fog, Black or Grey.

#TBL-4: Size: 60”w x 30”d x 29”h. **#TBL-5:** Size: 72”w x 30”d x 29”h.

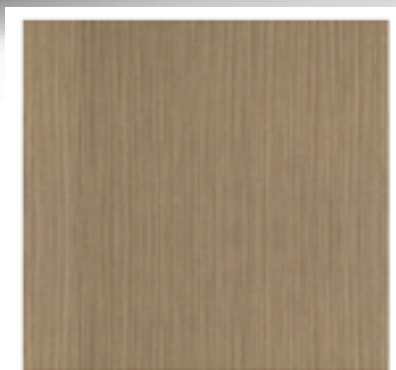

Linea Mocha (LM)



"E3" (Silver Fog Finish)

Power/USB Module Includes:
2 Power Receptacles with
1 Dual USB-A+C Charger
Standard Plug



#TBL-4: 60”w Table with Power. Price: \$ 1,064.00

#TBL-5: 72”w Table with Power. Price: \$ 1,110.00



Adult Area

Table Top Power & Charger Grommet Unit. Byrne #MX2B Series. Flush mount into top surface – Dual sided -Pop Up unit feature. Size: 8" x 8" x 3"d.

Mount one on each table – **centered in top**. Single Cord. 12 ft power cord – Plug in. Metal finish: Noted below. **(Yellow line shows wire management under top).**

(1) per worktable #TBL-4 & TBL-5. Total (2) units. +Add price for wire management.



Image shows 4 window unit per side.
2 power, 2 USB A+C . 15 amp power cord
with integrated circuit breaker.



White, Matte Storm or Black

#TBL-4: 60" w Table with Power. Price: \$ 1,795.00

#TBL-5: 72" w Table with Power. Price: \$ 1,840.65



#CH-2: Chair at worktables

Adult Area



Linea Mocha (LM)
Table Laminate



Balanced Beige Shell,
Beige Vinyl Uph. seat

JSI – Hoopz Series: Sled base stacking chair, armless, Poly shell perforated poly back with upholstered seat. Frame: Black or Chrome – TBD? .



Image- Hoopz black poly shell, black vinyl seat, black sled base frame

Poly Perforated Design Back, Shell in White with Blue Crypton upholstered seat



Linea Mocha (LM)

Hearthstone Grey Shell /Grey Poly shell seat



#CH-2: Chair at worktables

JSI – Hoopz Series: Shell color options

Upholstered seat: Mayer, Editor: color: TBD.
Frame: Black or Chrome

Adult Area



Linea Mocha (LM)

Laminate on worktables



EDITOR

Cinder



EDITOR

Slate



EDITOR

Topaz



EDITOR

Water



EDITOR

Midnight



EDITOR

Mineral

Poly Shell color options: Beige, Black, Green, White, Grey & Red



ADA Guidelines

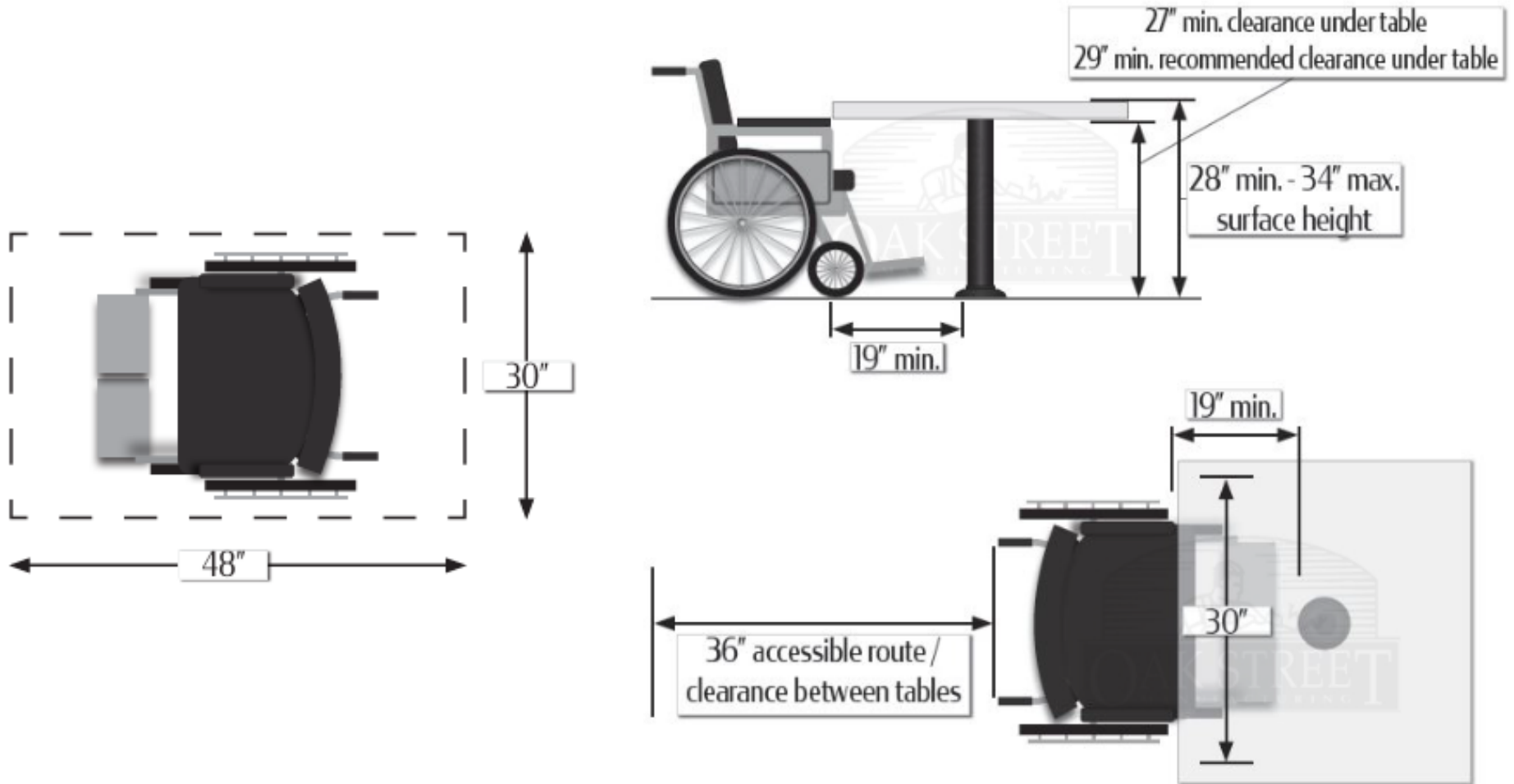

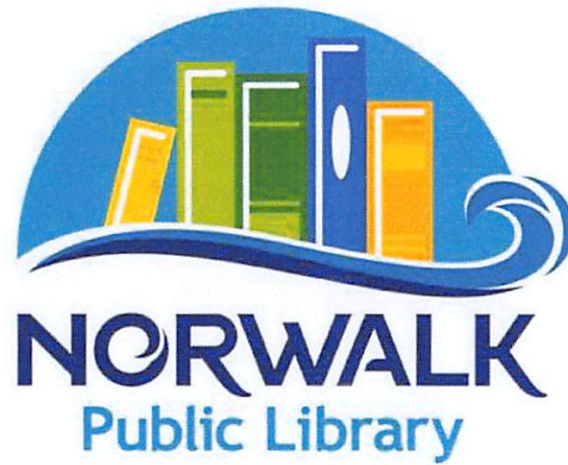

Main Branch - Furniture Images

May 9, 2025 - REVISED



Adult Area

Revised furniture drawing 4/28/25 from meeting notes.

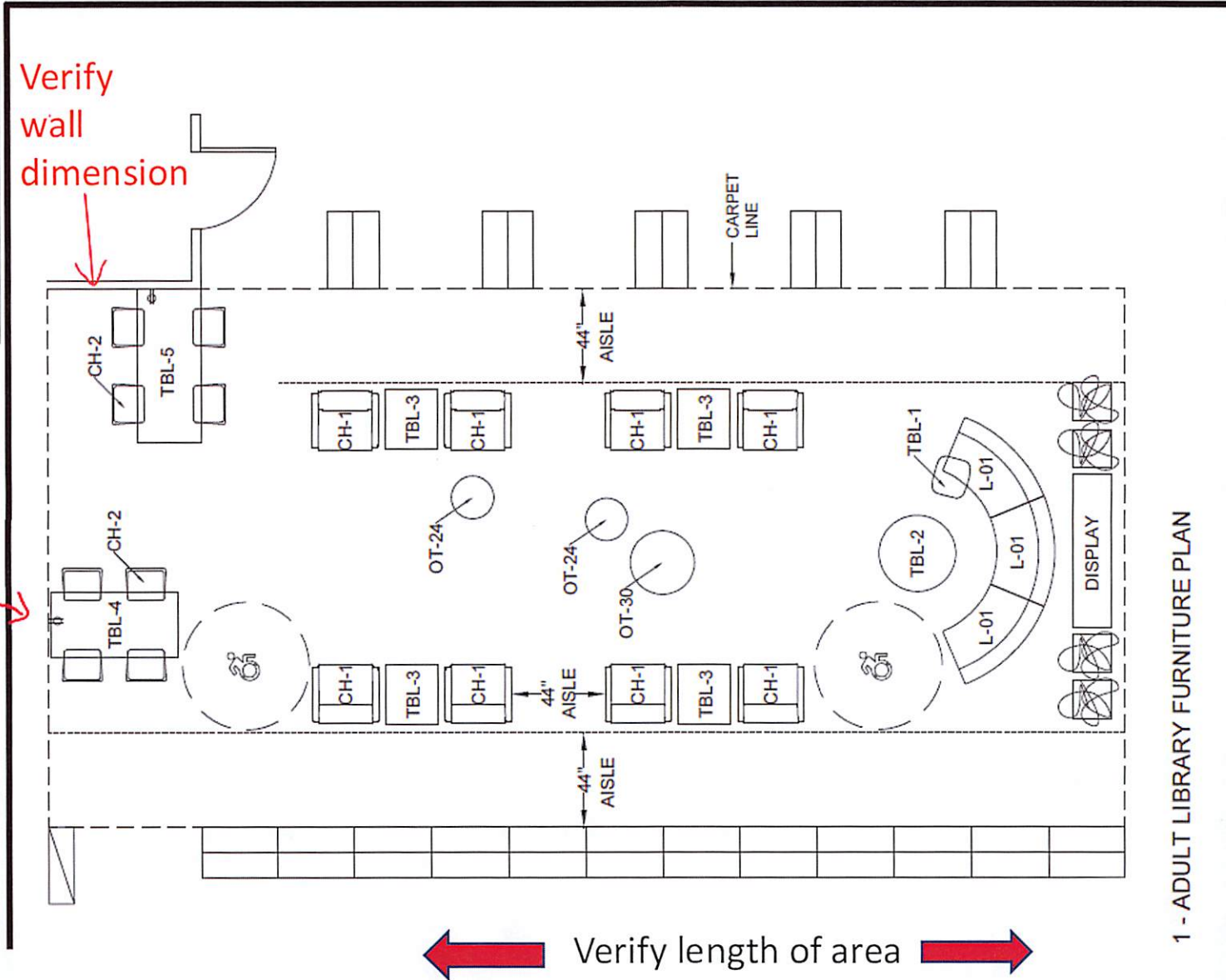

1 - ADULT LIBRARY FURNITURE PLAN

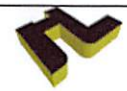

ROBERT H. LORD CO.

220 Chapel Road
 Manchester, CT 06042
 P: (860) 645-8700
 F: (860) 645-9100

NORWALK
 PUBLIC LIBRARY

1 BELDEN AVE.
 NORWALK, CT 06850

DRAWN: AK

SCALE: 3/16" = 1'-0"

REVISION: 2

DATE: 4/24/2025

FURNITURE
 PLAN



Adult Area

3-D Colored Rendering



Linea
Mocha
Laminata



Adult Area

3-D Colored Rendering

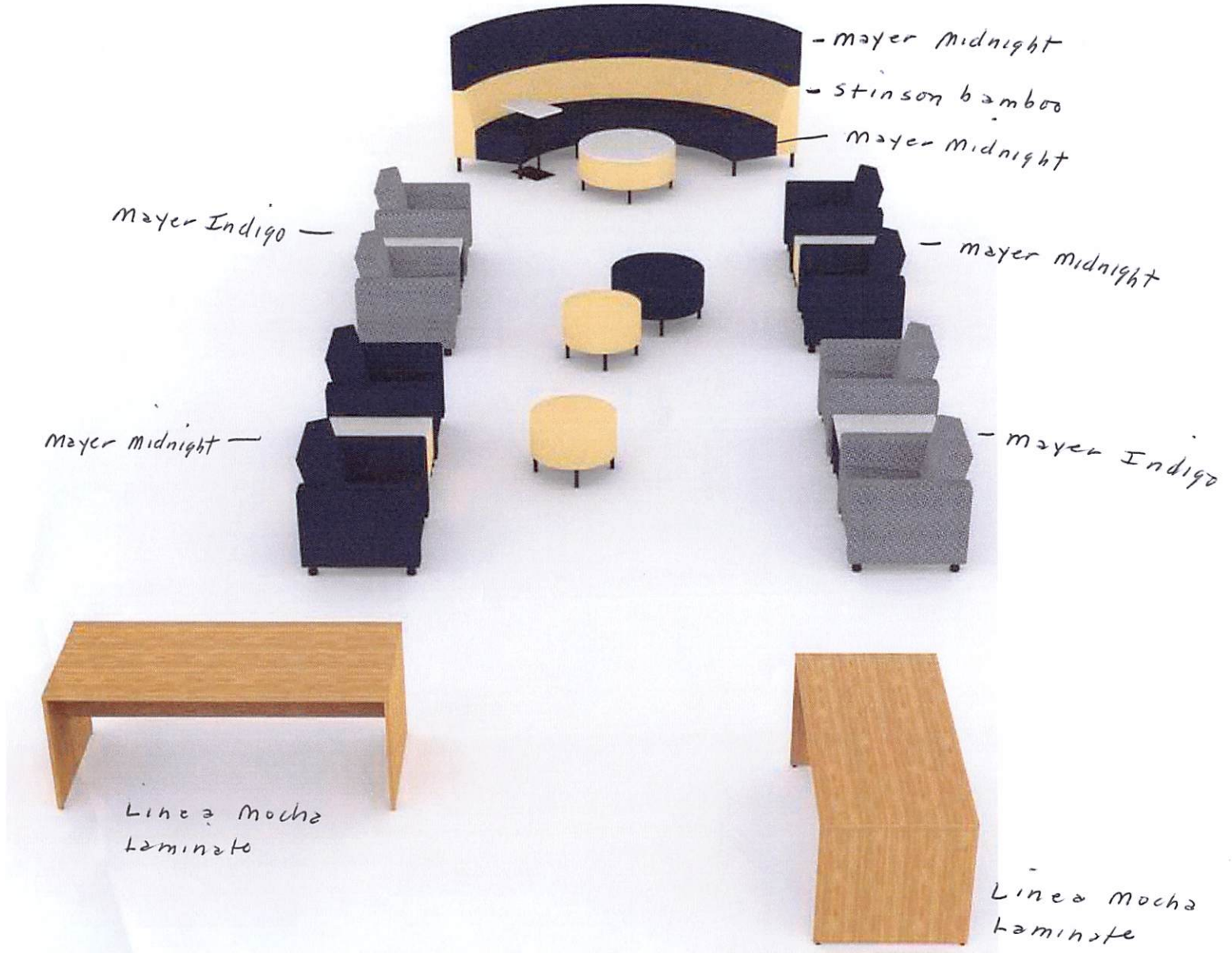

Adult Area

#L-01: Curved Lounge with wrapped tall back. OFGO Unify Series Modular Lounge. Segmented units to create the curves. Shown with 2-Tone materials. Made up of (3) 54" w x 28" d x 53" h. Black Metal Post Legs.



↗ Seat and Top Back:
Mayer – Editor- Midnight
#WC920-024

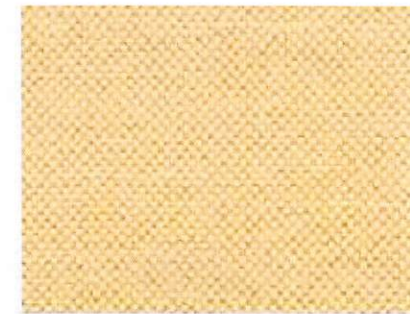

↘ Mid Center Back:
Stinson – Hopsack-Bamboo
#HOP-15

#CH-1 & #CH-1A: Lounge Chair - OFGO – Tribute Series Mobile Lounge Chair

Total Qty. (8) chairs: Single fabric. Black casters front and back on all chairs.

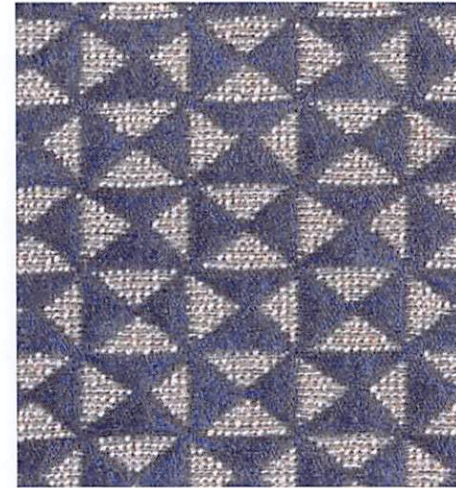

#CH-1: (4) Mayer – Ephesus – Indigo
#623-004 *ok -*



#CH-1A: (4) Mayer – Editor – Midnight
WC920-04 *ok -*

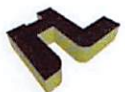

Adult Area

#TBL-1: Laptop Table – OFGO Studio - Pull Up Series Table.
20" w x 13" d x 27" h. TFL Laminate: Willow Gray #WG
Flat base slides easily under the Curved Benches and Lounge chairs. Metal post with flat base, Finish: Black OR Silver.



Laminate surface

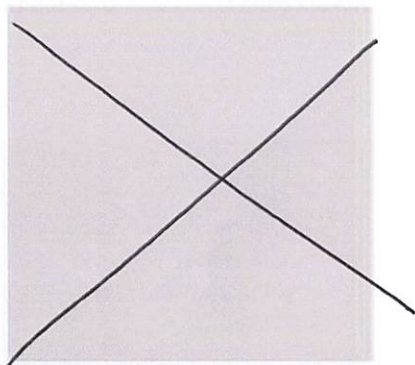

Willow Gray (WG)

Linea
Mocha

Metal Finish Options



Black

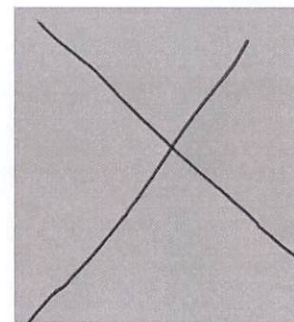

Silver



Adult Area

#TBL-2: OFGO Studio - Unify Series 36" round ottoman with laminate top (table), fabric wrapped side Hopsack Bamboo. Laminate: Willow Grey – to be confirmed. Qty. (1)

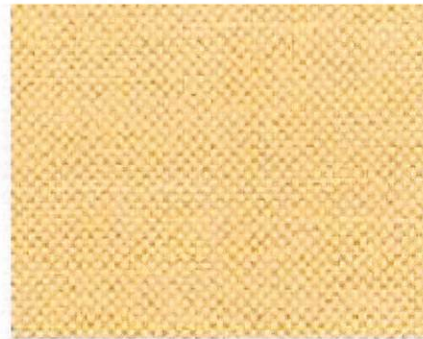

Stinson – Hopsack-Bamboo, #HOP-15

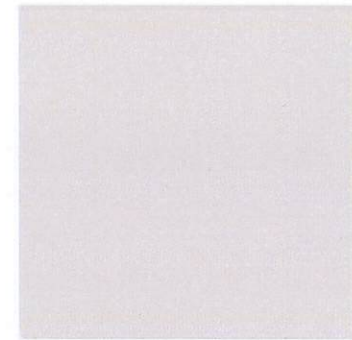

Willow Gray (WG)

Laminate top

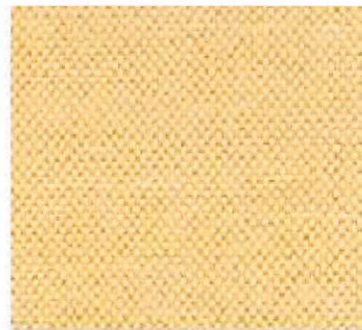
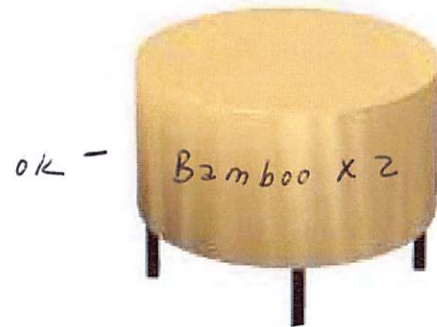

#OT-24: OFGO - Unify Series 24" round ottoman fabric side; Stinson Hopsack, Bamboo. Qty. (2).



#OT-30: OFGO – Unify Series 30" round ottoman fabric side; Mayer, Editor, Midnight. Qty. (1)



Adult Area

#TBL-3: Occasional Table. OFGO – Unify Series.

24" w x 26" d x 18" h Laminate top with vinyl or fabric sides.??

Black Metal post legs. Fabric Sides: TBD?

Laminate top: Willow Gray – or other options ???

Laminate top option: *Linea Mocha x 4*
 Need to confirm color

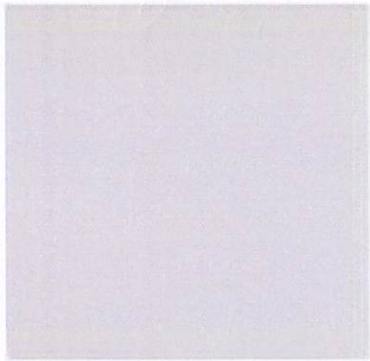

Willow Gray (WG)



Vinyl: Mayer, Key Largo, Wheat, Grd. 7



Vinyl: Mayer, Key Largo: Graphite Grd. 7

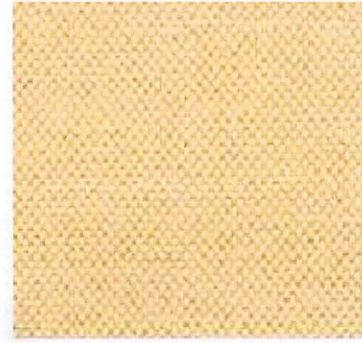

Fabric: Stinson, Hopsack: Bamboo – Grd. 11 *x 2*

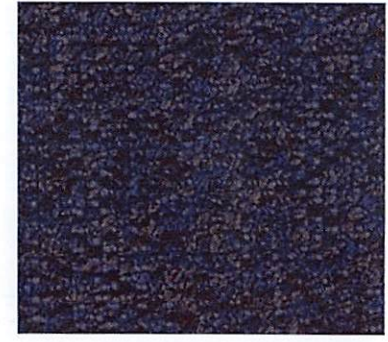

OR: Fabric: Mayer, Editor: Midnight - Grd. 10 *x 2*



OFGO Studio – Laminate Finishes Offered



Ginger Root (GN)
 Aura Finish
 Not available in HPL



Linea Mocha (LM)
 Embossed Finish
 Surface+™
 ECO+™



Linea Truffle (LT)
 Embossed Finish
 Surface+™
 ECO+™



Venetian Walnut (VW)
 EIR Finish
 Surface+™
 ECO+™

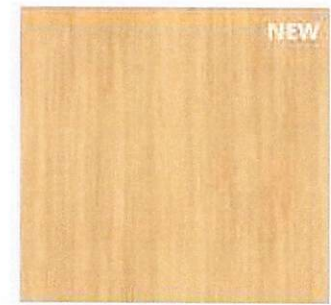

Golden Oak (GK)
 Embossed Finish
 Surface+™
 ECO+™

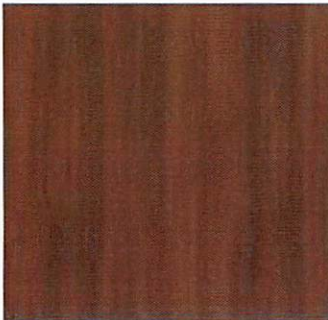

Hazelnut (HZ)
 Aura Finish
 Not available in HPL

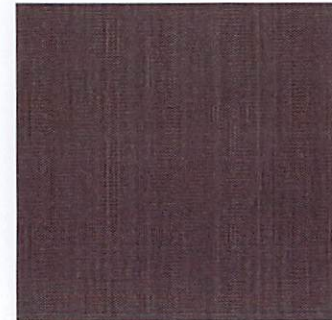

Linea Espresso (LE)
 Embossed Finish
 Surface+™
 ECO+™

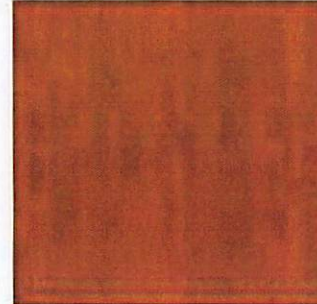

Cognac (CO)
 Smoothwood
 Surface+™
 ECO+™

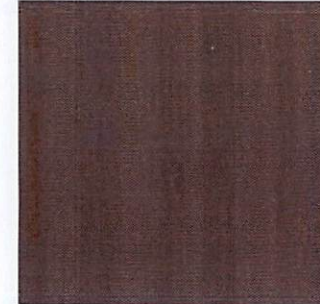

Tuxedo (TX)
 Smoothwood
 Surface+™
 ECO+™

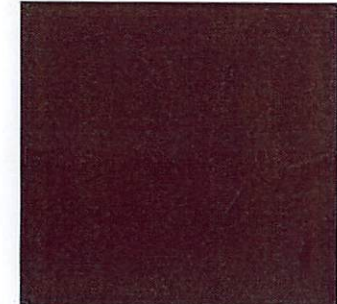

Chocolate Walnut (CW)
 Smoothwood
 Surface+™
 ECO+™



Hardrock Maple (HM)
 Smoothwood
 Surface+™
 ECO+™

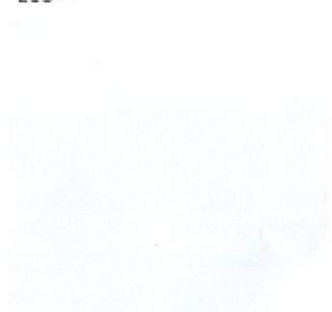

True White (TW)
 Surface+™
 ECO+™

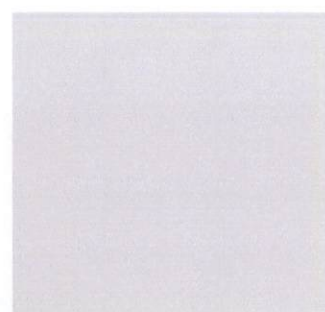

Willow Gray (WG)



Adult Area

Tables: OFGO - Lets Meet Series Community (Collaborative) Tables

Panel Ends, modesty panel – wire management run down inside of one end panel. Includes grommet with Flush power unit on top. 10 ft power cord – Plug in.

Centered. Laminate: Color TBD? #E3 - Power Box Finish: Silver Fog.

#TBL-4: Size: 60" w x 30" d x 29" h.

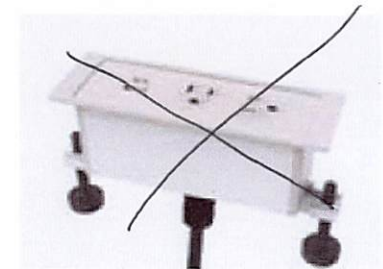

"E3" (Silver Fog Finish)

Power/USB Module Includes:
2 Power Receptacles with
1 Dual USB-A+C Charger
Standard Plug

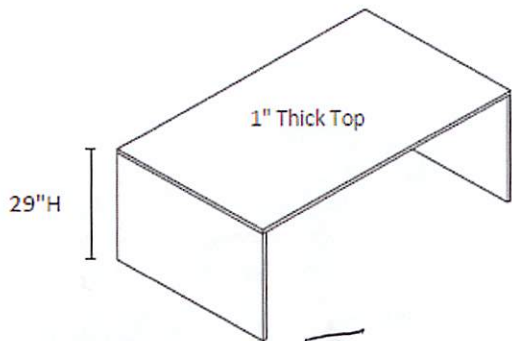

Collaborative Table

29" Height

1" Thick Top & Side Panels

Two 12" High Modesty Panels

Tables = Linea Mocha



Adult Area

Tables: OFGO - Lets Meet Series Community Work Tables

Panel Ends, modesty panel – wire management run down inside of one end panel. Includes grommet with pop up power unit on top. 10 ft power cord – Plug in. Centered. Laminate: Color TBD? #M3 - Power box finish: Silver

#TBL- 5: Size: 72" w x 30" d x 29' h.

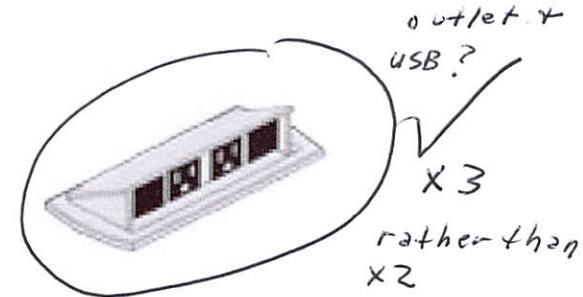
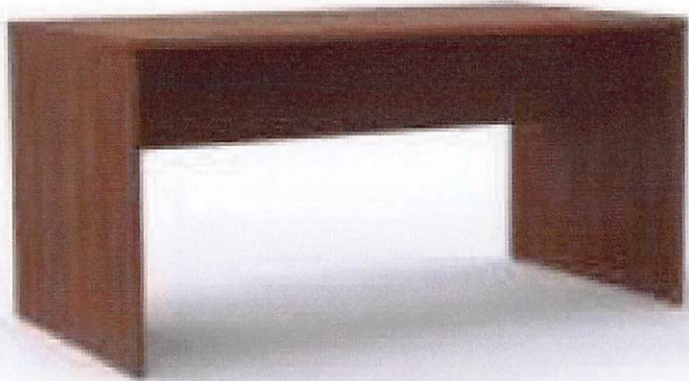

"M3" (Silver Finish)
Power/Data Module Includes:
2 Power Receptacles
2 Open Voice/Data Ports

Note: 1 will go in table closest to wall with electrical outlets and 2 will go in other tables.

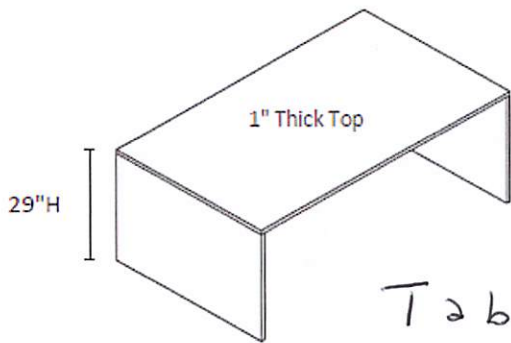

Collaborative Table
29" Height
1" Thick Top & Side Panels
Two 12" High Modesty Panels

Tables = Linea mocha



OPTION- #CH-2: Chair Options at worktables

Adult Area

KI – Calida Sled base chair

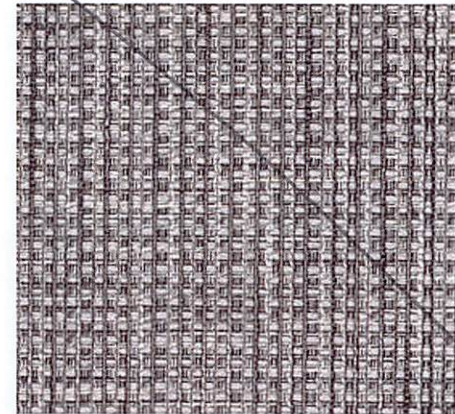

Pallas - Ode color Grit.

Adult Area

TBD??? #CH-2: Chair Options at worktables



Artopex – Vortex Sled base chair with full arms



9 to 5 – Cavo arm or armless guest chair option.

TBD??? #CH-2: Chair Options at worktables

Adult Area



Artopex – Minimax sled base chair with demi arms



9 to 5 Seating – Shuttle Series – Sled base chair with arms



JSI – Hoopz Sled base stacking chair, armless.

✓
x8
Add to Quote



Graded in Grade: M1
Pattern: M1 Mesh
Color/Style: Black M11
Material Type: Mesh
Vendor: 9to5 Seating
Backing: Other
Abrasion: 100,000

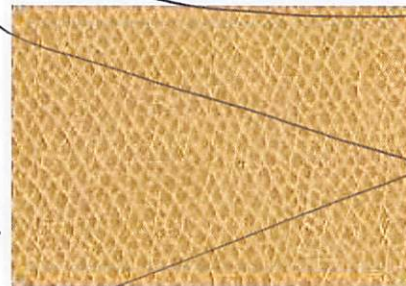

Graded in Grade: B
Pattern: Promenade
Color/Style: Fawn
Material Type: Textile
Vendor: 9to5 Seating
Backing: 70% Polyester, 30% Cotton
Abrasion: 200,000
Bleach Cleanability: BC 5:1

Remove from Quote

#PL-1 Accessories: Planters – create space dividers between walking areas and sitting – quiet areas.

Single, Double or Triple Planters

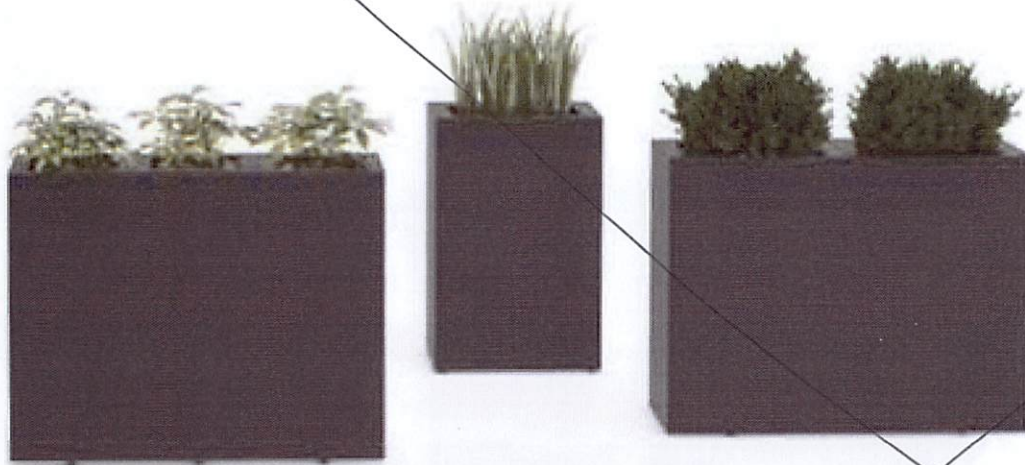

Magnuson Group accessories: Pic Series
 Planters with interior soil/water liners.
 Painted metal finishes. 27" h. Various widths.

PIC Body Finish Colors:

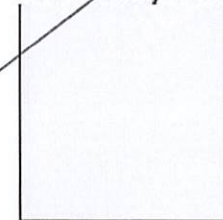

White



Silver



Black Grey

PIC-60-PL	26 15/16" x 11 7/8" x 11 7/8"	15 lbs.	Indoor single compartment painted steel square planter with internal liner and removable top.
PIC-2x60-PL-PL	26 15/16" x 23 5/8" x 11 7/8"	31 lbs.	Indoor double compartment painted steel square planter with two internal liners and removable tops.
PIC-3x60-PL-PL-PL	26 15/16" x 35 5/16" x 11 7/8"	50 lbs.	Indoor triple compartment painted steel square planter with three internal liners and removable tops.

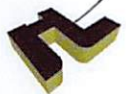

ADA Guidelines

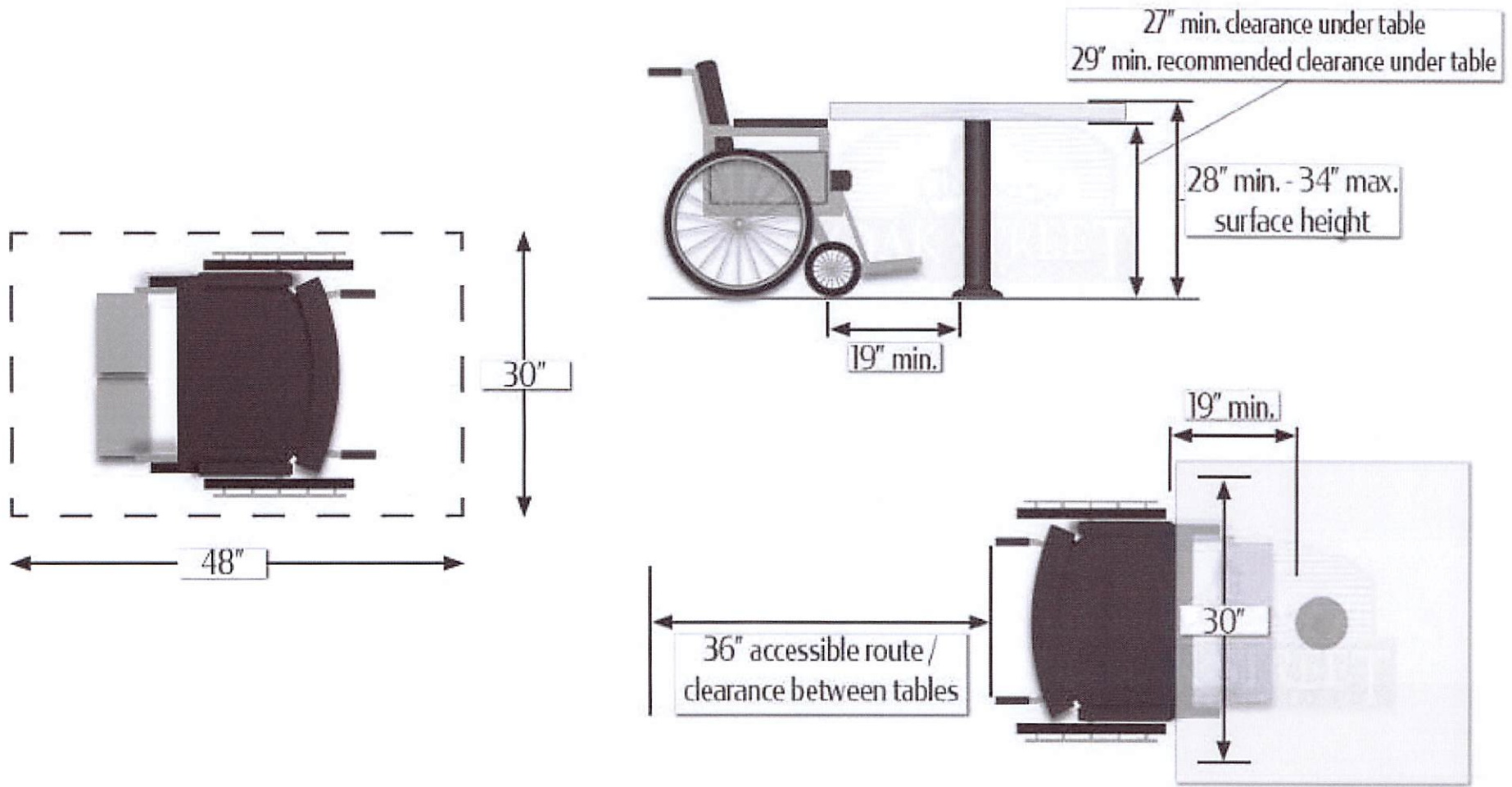



Robert H. Lord Company

220 Chapel Road
Manchester, CT 06042

Phone # (860) 645-8700
Fax # (860) 645-9100

www.rhlco.com

QUOTE

Date	Quote ID
3/19/2025	36082

Bill To	CN3011
Norwalk Public Library 1 Belden Ave. Norwalk, CT 06850	

Ship To	36082
Norwalk Public Library Sherelle Harris 1 Belden Ave. Norwalk, CT 06850	

Estimator	Cust P.O.	Terms	Sales Rep	Project Manager	Job Code
L. Bianchi		Net 30 from In...	LB	J Szabo	15 - CT #15PSX0...

Ref	Description	Qty	Cost	Total
	TAG: Adult Reading Area			
CHAIR #CH-1	OFGO - #5600-SF-1S-PPSL-CCSL-P18 - Tribute Series Lounge Chair - 2 Tone Material - Grd.10. (4) Locking Casters. Metal Column Legs, Size: 31"w x 31"d x 32"h. Includes Bar Pull Handle on Back. Single Fabric. - Material: Mayer - Editor Color: Midnight # WC920-024. - Caster: Black	4 OK	1,126.74	4,506.96
CHAIR #CH-1A	OFGO - #5600-SF-1S-CCSL-P18 - Tribute Series Lounge Chair - 2 Tone Material, Grd. 12, (4) Locking Casters, 31"w x 31"d x 32"h, Includes Pull Bar Handle on Back. Single Fabric. - Material: Mayer - Ephesus Color: Indigo (BowTie Design) #623-004 - Casters: Black	4 OK	1,237.51	4,950.04
Laptop #TBL-1	OFGO - #PU201226-RC-B - Vita Series Laptop Table - Flat Base, 20"w x 12"d x 26.5"h. TFL Laminate, 1" Thk Top - Laminate: Willow Gray Linea mocha - Metal Paint Finish: TBD Black - Black, Silver, or White?	2 OK	385.60	771.20

Due to current market volatility of raw materials and freight costs, pricing is valid for 30 days from date of quote. A revised quote will be provided after 30 days.

ACCEPTED BY: _____ DATE: _____

CUSTOMER PO: _____

Subtotal
Sales Tax (6.35%)
Total



Robert H. Lord Company

220 Chapel Road
Manchester, CT 06042

Phone # (860) 645-8700
Fax # (860) 645-9100

www.rhlco.com

QUOTE

Date	Quote ID
3/19/2025	36082

Bill To	CN3011
Norwalk Public Library 1 Belden Ave. Norwalk, CT 06850	

Ship To	36082
Norwalk Public Library Sherelle Harris 1 Belden Ave. Norwalk, CT 06850	

Estimator	Cust P.O.	Terms	Sales Rep	Project Manager	Job Code
L. Bianchi		Net 30 from In...	LB	J Szabo	15 - CT #15PSX0...

Ref	Description	Qty	Cost	Total
Table #TBL-3	OFGO - #4000-OT-1S-TM-HHSL - Unify Series Side Table. 24" x 28" x 18"h, TFL Laminate Top, Upholstered Sides, Post Metal Legs, Grd. 11 - Laminate Top: Stinson Hopsack? Linea Mocha - Color: TBD? Bamboo x 2 and Midnight x 2 - Paint legs: Black	4 OK	782.82	3,131.28
Table #TBL-2	OFGO - #4000-OR-36-TM-HHSL - Unify Series Round Table - 36" dia x 18"h, TFL Laminate Top, Upholstered Sides, Grd. 11, Post Metal Legs - Laminate Top: TBD Linea Mocha - Sides: Stinson Hopsack? Mayer Midnight - Color: TBD - Paint Legs: Black	1 OK	1,024.93	1,024.93
Curved Lounge #L0-1	OFGO - #4053-SF-IC-45D-HHSL - Unify Series Inside Curved Bench - Armless, 54"w x 28"d x 53"h, Overall Curve: 10' 4" wide. Two Tone- Combined Grd 11. Ganged together, brackets separate. Metal Post Legs. - Seat Material: Mayer Editor - Color: Midnight OK - Middle Back Cushion: Stinson, Hopsack - Color: Bamboo OK - Upper Back: Mayer, Editor - Color: Midnight OK - Paint Legs: Black	3 OK	2,442.32	7,326.96

Due to current market volatility of raw materials and freight costs, pricing is valid for 30 days from date of quote. A revised quote will be provided after 30 days.

Subtotal
Sales Tax (6.35%)
Total

ACCEPTED BY: _____ DATE: _____

CUSTOMER PO: _____



Robert H. Lord Company

220 Chapel Road
Manchester, CT 06042

Phone # (860) 645-8700
Fax # (860) 645-9100

www.rhlco.com

QUOTE

Date	Quote ID
3/19/2025	36082

Bill To	CN3011
Norwalk Public Library 1 Belden Ave. Norwalk, CT 06850	

Ship To	36082
Norwalk Public Library Sherelle Harris 1 Belden Ave. Norwalk, CT 06850	

Estimator	Cust P.O.	Terms	Sales Rep	Project Manager	Job Code
L. Bianchi		Net 30 from In...	LB	J Szabo	15 - CT #15PSX0...

Ref	Description	Qty	Cost	Total
Brackets	OFGO - #AC-STs-PR - Ganging Brackets, sold in pairs for Unify Series Curved Benches, Black Paint	3 OK	41.00	123.00
OT-24	OFGO - #4000-OR-24-HHSL - Unify Series Round Ottoman - 24"d x 18"h. Grd. 11, Post Legs - Fabric: Stinson, Hopsack - Color: Bamboo - Paint Legs: Black	2 OK	819.74	1,639.48
OT-30	OFGO - #4000-OR-30-HHSL - Unify Series Round Ottoman - 30"d x 18"h. Grd. 10, Post Legs - Fabric: Mayer - Editor Color: Midnight - Paint Legs Finish: Black	1 OK	896.75	896.75
TBL-4	OFGO - #LM603029-GM-GM-12P - Lets Meet Collaborative Table - 60"w x 30"d x 29"h, to include center power grommet #M3 Module. Full Panel End Bases. Wire Management and 12"h Modesty Panel. HPL Laminate. 1" Thk Top and Panel Sides. - Laminate: TBD Linea Mocha	1 OK	680.00	680.00
TBL-5	OFGO - #LM723029-GM-GM-12P-M3 - Lets Meet Collaborative Table - 72"w x 30"d x 29"h, to include center power grommet #M3 Module. Full Panel End Bases. Wire Management and 12" Thk Top and Panel Sides. - Laminate: TBD Linea Mocha	1 OK	730.59	730.59

Due to current market volatility of raw materials and freight costs, pricing is valid for 30 days from date of quote. A revised quote will be provided after 30 days.

ACCEPTED BY: _____ DATE: _____

CUSTOMER PO: _____

Subtotal
Sales Tax (6.35%)
Total

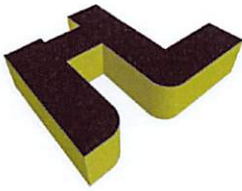

Robert H. Lord Company

220 Chapel Road
Manchester, CT 06042

Phone # (860) 645-8700
Fax # (860) 645-9100

www.rhlco.com

QUOTE

Date	Quote ID
3/19/2025	36082

Bill To	CN3011
Norwalk Public Library 1 Belden Ave. Norwalk, CT 06850	

Ship To	36082
Norwalk Public Library Sherelle Harris 1 Belden Ave. Norwalk, CT 06850	

Estimator	Cust P.O.	Terms	Sales Rep	Project Manager	Job Code
L. Bianchi		Net 30 from In...	LB	J Szabo	15 - CT #15PSX0...

Ref	Description	Qty	Cost	Total
TBL - POWER	OFGO - #AC-HDMI-COUPLER - Lets Meet HDMI Coupler - for power grommet boxes on tables. 10ft Cord. #G3 - Silver Grommet, comes with 10ft black cord.	2 3	60.15	120.30
CH-2	# M3 TBD → JSI Hoopz sled based armless	8 OK		0.00
PL-1 OPTION	Magnuson Group - #213109-PIC-60 - Pic Series Single Unit Planter - Metal, 12"w x 12"d x 27"h. 16 Gallon Body. Removable Top. Freight Included. Body Paint: TBD Top Paint: TBD	4 NO	849.00	3,396.00
<u>REMOVE</u>				
PL-2 OPTION	Magnuson Group - #213147-PIC 3x60-PL-PL-PL - Pic Series Single Planter - Metal, 12"w x 12"d x 27"h, 48 Gallon Body. Removable Top. Freight Included. Del. & Installation is included - single trip per all items on quote. Based on CT ST contract. Lead Times to Ship: Est. 10-11 weeks to ship. Ref: OFGO Q# 11826-V3 Chris Mason Ref: Magnuson Grp. Q# T002451	2 NO	1,755.00	3,510.00
<u>REMOVE</u>				

Add to quote

Due to current market volatility of raw materials and freight costs, pricing is valid for 30 days from date of quote. A revised quote will be provided after 30 days.

Subtotal	\$32,807.49
Sales Tax (6.35%)	\$0.00
Total	\$32,807.49

ACCEPTED BY: _____ DATE: _____

CUSTOMER PO: _____