



**PUBLIC HEARING FOLLOWED  
BY REGULAR MEETING – PUBLIC WORKS COMMITTEE  
AGENDA**

**FEBRUARY 3, 2026, 7:00 PM  
BY ZOOM VIRTUAL MEETING**

To allow public access, anyone may access a meeting by telephone and/or Zoom, or a recording in the City of Norwalk YouTube channel. Specific instructions and links can be found at [norwalkct.gov/meetings](https://norwalkct.gov/meetings).



Members of the public may call in to participate. Callers will not be able to see the meeting participants. All participants will be muted upon entering the meeting. To speak, dial \*9 on the phone and you will be called on by the host of the meeting during the public comment section. All speakers must state their name and address. Comments must be on a topic on the agenda, and are limited to three minutes. Anyone disrupting the orderly conduct of the meeting, including by using threatening, hateful, or sexually-explicit language, will be removed. Please find the information using the link above.



Members of the public who wish to provide "live comments" may also use the Zoom meeting platform. All participants will be muted upon entering the meeting. To speak, click the "raise your hand indicator" and you will be called by the host of the meeting during the public comment section. All speakers must state their name and address. Comments must be on a topic on the agenda, and are limited to three minutes. Anyone disrupting the orderly conduct of the meeting, including by using threatening, hateful, or sexually-explicit language, will be removed. Please find the information using the link above.



Members of the public who wish to provide public comment are encouraged to submit those via email in advance of the meeting. For these comments to be included into the record, they must be submitted by 12:00 p.m. the day of the meeting. Please email Monique Cipriano at [mcipriano@norwalkct.gov](mailto:mcipriano@norwalkct.gov) with the subject line "Public Comment" to provide written public comment prior to the meeting.

**I. CALL TO ORDER**

**II. ROLL CALL**

**III. PUBLIC HEARING**

- A.** Public Hearing for the Honorary Naming of Lincoln Avenue Extension to Master Chief Alexander Restrepo Way. The Public Hearing shall be conducted in order to hear all parties interested in commenting on the proposed Honorary Street naming and to take such action on said naming that the Committee may deem advisable.
- B.** Public Hearing for the Honorary naming of a portion of West Avenue from Wall Street to Connecticut Avenue/Mathews Park to Stanley Seligson Way. The Public Hearing shall be conducted in order to hear all parties interested in commenting on the proposed Honorary Street naming and to take such action on said naming that the Committee may deem advisable.

**IV. ACCEPTANCE OF MINUTES**

- A. Regular Meeting: December 2, 2025**

**V. PUBLIC PARTICIPATION**

**VI. NEW BUSINESS**

- A. Authorize the Mayor, Barbara C. Smyth to enter into a Subordination Agreement and such other instruments incidental thereto with the Housing Authority ("NHA") for the**

city of Norwalk with respect to the City's easements at 20 Day Street in connection with NHA's ELUR Application to DEEP.

- B. Approve the Honorary Naming of Lincoln Avenue Extension to Master Chief Alexander Restrepo Way.
- C. Approve the Honorary Naming of the portion of West Avenue from Wall Street to Connecticut Avenue/Mathews Park to Stanley Seligson Way.
- D. Acknowledge the receipt of the request for the Honorary Naming of Knight Street to Cutie Mae Jordan Way.
- E. Schedule a Public Hearing for the Honorary Naming of Knight Street to Cutie Mae Jordan Way. The Public Hearing shall be conducted in order to hear all parties interested in commenting on the proposed Honorary Street naming and to take such action on said naming that the Committee may deem advisable. The Public Hearing is scheduled for Tuesday, March 3, 2026 at 7:00 P.M. by way of Videoconference/Teleconference.
- F. 1. Authorize the Mayor, Barbara C. Smyth, to execute the 4<sup>th</sup> Amendment to the December 12, 2023 agreement between the City of Norwalk and M. Rondano Inc. for Purchasing Project 4322, DRG 2023-3 On Call Drainage at Various Locations for a sum not to exceed \$1,124,616.15.

09 20 4062 5777 C0361  
09 24 4062 5777 C0361  
09 24 4021 5777 C0302  
09 25 4021 5777 C0302  
09 26 4021 5777 C0302  
09 24 4021 5777 C0021  
09 25 4021 5777 C0021  
09 26 4021 5777 C0021  
09 21 4021 5777 C0440  
09 22 4021 5777 C0440  
09 24 4021 5777 C0440  
09 25 4021 5777 C0440  
09 26 4021 5777 C0440  
09 20 4027 5777 C0643  
09 21 4021 5777 C0643  
09 22 4021 5777 C0643  
09 25 4021 5777 C0643  
09 26 4021 5777 C0643  
09 25 4021 5777 C0715  
09 26 4021 5777 C0715

2. Authorize the Chief of Operations and Public Works to execute orders on the contract with M. Rondano, Inc. for project DRG2023-3 On-Call Drainage Improvements at Various Locations for a sum not to exceed \$112,461.62.

Account No.

09 20 4062 5777 C0361  
09 24 4062 5777 C0361  
09 24 4021 5777 C0302  
09 25 4021 5777 C0302

09 26 4021 5777 C0302  
09 24 4021 5777 C0021  
09 25 4021 5777 C0021  
09 26 4021 5777 C0021  
09 21 4021 5777 C0440  
09 22 4021 5777 C0440  
09 24 4021 5777 C0440  
09 25 4021 5777 C0440  
09 26 4021 5777 C0440  
09 20 4027 5777 C0643  
09 21 4021 5777 C0643  
09 22 4021 5777 C0643  
09 25 4021 5777 C0643  
09 26 4021 5777 C0643  
09 25 4021 5777 C0715  
09 26 4021 5777 C0715

- G. Authorize the Mayor, Barbara C. Smyth, to execute the 1st Amendment to the July 20th, 2023 agreement between the City of Norwalk and NewGen Strategies and Solutions, LLC for Municipal Solid Waste Disposal Consulting Services for a sum not to exceed \$33,300.

Account No. 01 40 43 5298

VII. REPORTS

- A. 2025 Metrics
- B. Snow Operations
- C. Tree Operations and Programming
- D. Monthly Solid Waste Report
- E. Food Scrap Drop-Off Report
- F. Ongoing Projects Status

VIII. DISCUSSION

IX. ADJOURNMENT

UPCOMING MEETINGS

Tuesday, March 3, 2026 7:00 p.m.

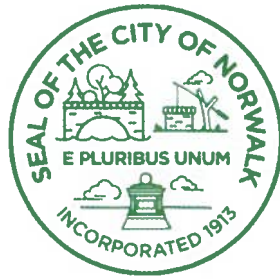

## Contract Staff Summary

<b>Department/Staff Contact</b>	DPW Engineering / Paul Sotnik x47891
<b>Common Council Committee</b>	Public Works Committee
<b>Date Approved by Committee</b>	
<b>Purpose/Scope</b>	Honorary Naming of Lincoln Avenue Extension to Master Chief Alexander Restrepo Way
<b>Vendor</b> (Indicate if new or existing vendor)	N/A
<b>Term of Contract</b>	
<b>Method of Procurement</b> (Indicate if sole source)	
<b>Cost of Contract</b>	
<b>Funding Source/Account Number</b>	
<b>Additional Information/Other Details</b>	Public Hearing 2/3/2026



City of Norwalk  
Paul Sotnik, P.E.  
*Senior Civil Engineer / Department of Engineering*  
125 East Avenue  
Norwalk, CT 06856-5125  
Office Telephone: (203) 854-7891  
[www.norwalkct.gov](http://www.norwalkct.gov)  
E-Mail: [psotnik@norwalkct.gov](mailto:psotnik@norwalkct.gov)

## MEMORANDUM

**TO:** Vanessa Valadares, P.E. - Chief of Operations and Public Works

**FROM:** Paul L. Sotnik, P.E. - Senior Civil Engineer 

**CC:** James Meehan, P.E. - Principal Engineer

**REF:** Master Chief Alexander Restrepo Way  
Public Hearing and Action Item For the Honorary Naming of Lincoln Avenue Extension

**DATE:** January 16, 2026

---

Ms. Michelle Petrides delivered a request letter and package of supporting backup information concerning the above referenced topic on October 9, 2025, requesting that Lincoln Avenue Extension be named Master Chief Alexander Restrepo Way in honor of his military service in the United States Navy in Seal Team SIX as a Master Chief.

The proposed Honorary Street Name sign would be installed at the following location. I have attached a map for reference.

- On Lincoln Avenue Extension at the intersection of Lowndes Avenue.

On December 2, 2025 at their regularly scheduled meeting, the Public Works Committee of the City Council acknowledged the receipt of the request for the Honorary naming of Lincoln Avenue Extension to Master Chief Alexander Restrepo Way and called for the scheduling of a Public Hearing on Tuesday, February 3, 2026 at 7:00 P.M. concerning the topic in order to hear all parties interested in commenting on the proposed Honorary Street naming and to take such action on said naming that the Committee may deem advisable.

Therefore, I would like to request that the following Items be included on the agenda for the February 3, 2026 meeting of the Public Works Committee of the City Council for approval.

### Public Hearing

Conduct a Public Hearing to hear all parties interested in commenting on the proposed Honorary Street naming of Lincoln Avenue Extension to Master Chief Alexander Restrepo Way at 7:00 P.M.



**DEPARTMENT OF  
ENGINEERING**

City of Norwalk  
**Paul Sotnik, P.E.**  
**Senior Civil Engineer / Department of Engineering**  
125 East Avenue  
Norwalk, CT 06856-5125  
Office Telephone: (203) 854-7891  
[www.norwalkct.gov](http://www.norwalkct.gov)  
E-Mail: [psotnik@norwalkct.gov](mailto:psotnik@norwalkct.gov)

New Business

Approve the Honorary naming of Lincoln Avenue Extension to Master Chief Alexander Restrepo Way.

I have attached a copy of Chapter 95 Streets and Sidewalks Article II Honorary and Historic Naming of Streets for reference.

If you have any questions, please do not hesitate to contact me.

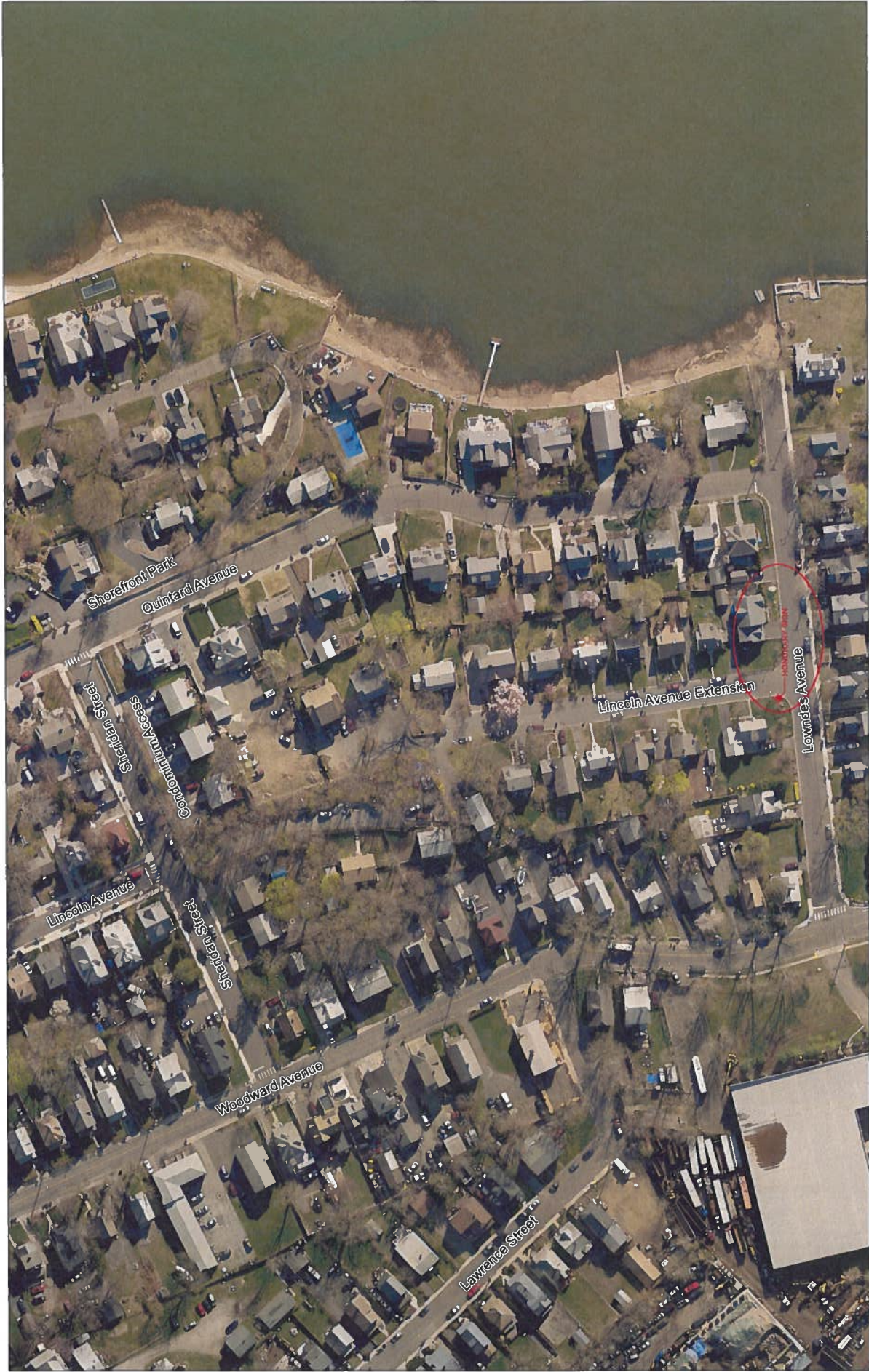

2019 AERIAL PHOTO DATA

1 inch = 50 feet



# MASTER CHIEF ALEXANDER RESTREPO WAY

Michelle Petrides  
194 East Avenue  
Norwalk CT 06855  
203.253.2088

Chief of Operations and Public Works  
125 East Avenue  
Norwalk Ct 06856

Dear Vanessa Valadares,

I hope this letter finds you well. My name is Michelle Petrides and I am writing you today to request naming a street sign.

In accordance to ordinance 95-39, I believe we have met the requirements to make such request. Alexander Restrepo grew up with his family on Lexington Ave ext. although Alex was predeceased by his mother, his father, Horatio still resides in their family home. Alex

passed away suddenly on January 27, 2020. Alex graduated from Brian McMahon High School, whom of which honored him posthumously for being a stand out athlete, but more importantly for his dedicated service in the U.S. Navy. Alex was handpicked to be a part of the first Seal Team Six.

I have enclosed his obituary, which summarizes Alex's 25 years of military service, as well as other documents both public and personal so that you may have more insight as to why this is a special and well deserved honor for him, but most importantly his family.

I am requesting that Lexington Avenue ext. also be named "Master Chief Alexander Restrepo Way" or "MCPON Alexander Restrepo way".

I am aware that there are several steps in procedure. I hope that we can be put on the next public works meeting agenda, with your blessing.

I will bring my petition at that time or at the time of the Public hearing at your request. Thank you for taking the time to read my request. I truly believe if anyone deserves a street sign, it's Alex. I appreciate your attention to this matter and look forward to hearing from you soon.

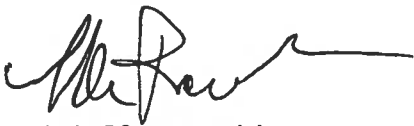

Michelle Petrides  
Michellemaggio4@gmail.com

RECEIVED  
OCT 09 2025  
PUBLIC WORKS

Some things come with age.  
Some others don't.  
Learn the early signs of Alzheimer's.

10signs.org  
ALZHEIMER'S ASSOCIATION



## THE HOUR

🔍 Search by Name

[Restrepo](#) / [Alexander Restrepo](#)

# Alexander Restrepo

🌸 Send Flowers

➦ Share

⊕ Follow

## Alexander Restrepo Obituary

**A**lexander Restrepo Master Chief (SEAL-Ret.) Alexander Restrepo passed away suddenly January 27, 2020. He was born in Costa Rica, grew up in Connecticut, and spent much of his military career in Virginia Beach. Master Chief Restrepo enlisted in the U.S. Navy in 1977, and after a brief tour in the surface navy, he volunteered for Basic Underwater Demolition/SEAL training in Coronado, CA. He served over twenty-five years in Underwater Demolition and SEAL Teams earning a distinguished record of accomplishments. Upon retirement from active duty, as a decorated Master Chief Petty Officer, he pursued a second

career supporting several U.S. Government Agencies and a wide range of private corporations worldwide, including work in Iraq and in the suppression of illegal immigration and drug smuggling near the United States southern border. During his military service, he deployed as a platoon member in Underwater Demolition Team 21 to the Caribbean and the Mediterranean until he was handpicked to join the recently formed SEAL Team SIX, in which he served in increasingly significant leadership positions. Master Chief Restrepo led, and participated in, multiple classified worldwide operations in support of U.S. and foreign governments, militaries, and agencies. He conducted counter insurgency operations in El Salvador and Honduras, combat operations in Granada and Panama; and high-level national security missions involving counter terrorism, counter insurgency and counter narcotics operations worldwide. Most notably, he was recognized as one of the foremost experts in the world in the application of Explosive Breaching, while leading a division responsible for combat engineering, explosives development, and the tactical use of explosives. Alex was a professional, reliable, and loyal teammate, as well as a devoted family man who had the admiration and respect of his fellow warriors. He is leaving indelible memories of shared life experiences in the service of his country and his family. He is survived by his wife Amy, his children Alexandra, Kyle, and Lauren; his father Horacio; his sister Adriana L'Archevesque, her husband Lee and children, Emma, Lily, Lia, and Grace; his brother Marco and his wife Katie and children Nicolas and Elijah; his cousin Victor Fallas, wife Karolyn and sons Tyler and Dean. Alex was predeceased by his mother Iris. A funeral service will be held at Arlington National Cemetery at a later time.

To plant trees in memory, please visit the [Sympathy Store](#).

Published by The Hour on Jan. 31, 2020.

### **Restrepo Pages**

See more records on Ancestry®



## **Alexander Restrepo**

### **Class of 1977**

Alexander Restrepo is being honored posthumously for his dedicated and notable service in the U.S. Navy for over 25 years.

While a student at Brien McMahon, Alexander was a standout athlete, playing outside linebacker on the football team and wrestled 132 pounds on the 1977 State Champion wrestling team. In addition, Alexander earned an individual State champion title in his weight class.

After graduating in 1977, Alexander enlisted in the U.S. Navy in San Diego, CA. After a brief tour in the surface Navy, he volunteered for Basic Underwater Demolition/SEAL training in Coronado, CA. He served over twenty-five years in the Underwater Demolition and SEAL Teams earning a distinguished record of accomplishments.

During his military service he was deployed as a platoon member in Underwater Demolition Team 21 to the Caribbean and the Mediterranean until he was handpicked to join the recently formed SEAL Team SIX, in which he served in increasingly significant leadership positions. Master Chief Restrepo led, and participated in, multiple classified worldwide operations in support of the U.S. and foreign governments, militaries, and agencies. He conducted counter insurgency operations in El Salvador and Honduras, combat operations in Granada and Panama and high-level national security missions involving counter terrorism, counter insurgency, and counter narcotics operations worldwide. He was recognized as one of the foremost experts in the world in the application of Explosive Breaching, while leading a division responsible for combat engineering, explosives development and the tactical use of explosives.

Upon retirement from active duty, as a decorated Master Chief Petty Officer, Alexander pursued a second career supporting several U.S. Government Agencies and a wide range of private corporations worldwide, including work in Iraq and in the suppression of illegal immigration and drug smuggling near the U.S. Southern border.

Alexander died suddenly on January 27, 2020, and was laid to rest in Arlington National Cemetery. He is remembered as a reliable and loyal teammate, classmate, and a great friend to all that knew him.

The Brien McMahon High School Alumni Association is proud to include Alexander Restrepo in the 2023 Hall of Fame.



Alex (R) in Kurdistan.



Ronald Young March 22, 2020

 Share



BMHS 1974 Football Team. Alex is #23 - third row center



Manuel Allende February 3, 2020

 Share



January 31, 2020

**May your rest in Eternal Peace in Frogman Heaven Master CPO  
Restrepo.**

**HooYah!**

**Erasmio "Doc" Rioja**

 Share

◆ AI Overview



An obituary for Alexander Restrepo of Norwalk, CT, who died on January 27, 2020, is available on [Legacy.com](#) and was published in The Hour newspaper in Virginia Beach, VA. He was a veteran of the U.S. military, serving in counterinsurgency operations and as a member of the recently formed SEAL Team SIX. His military career involved deployments to El Salvador, Honduras, Panama, and the Caribbean.

**Key Details:**

- **Name:** Alexander Restrepo
- **Date of Death:** January 27, 2020
- **Location:** Norwalk, CT
- **Service:** U.S. military, including counterinsurgency and SEAL Team SIX operations

For further details, you can visit

[Legacy.com](#).

**Alexander Restrepo  
Obituary (2020) - Virgini...**

Jan 31, 2020 — How to support Alexander's loved ones. Honor a...

Legacy.com



Ne  
al  
Oc  
th  
TH

Q obituary for alexander restrepo norwal ct — Private

## Chapter 95. Streets and Sidewalks

### Article II. Honorary and Historic Naming of Streets

[Adopted 10-28-2014]

#### § 95-37. Purpose.

The purpose of this article is to establish guidelines and formalize procedures when considering the honorary or historic naming or renaming of a City-owned or controlled street or roadway, administered under the responsibility charged to the Public Works Committee of the Common Council.

#### § 95-38. Policy and considerations.

[Amended 4-14-2020]

If a City street or roadway is to be named in honor of an individual, it is generally required that such individual has made a significant contribution to the community through public service and deeds, and is respected for his or her accomplishments and good conduct. Consideration shall be given to individuals who have made recent accomplishments and contributions as well as individuals with historic ties to the City. An individual shall be deceased at least one year prior to the naming unless the Common Council determines by a two-thirds-majority plus one (11 votes) that a living individual or a person who has been deceased less than one year deserves the honor. Groups should not be in a position to influence the process by funding of past or future operations of the street or roadway, and it is ultimately important for the City to avoid any perception of improper manipulation, special favor, vested interest, or endorsement of businesses, products or services.

#### § 95-39. Procedure.

[Amended 4-14-2020]

Naming of City streets or roadways shall proceed as follows:

- A. The proposed naming of a City street or roadway shall be placed on a Public Works regular meeting agenda for discussion and review. In the event that the street or roadway to be named is located within a City park, the proposed naming shall be placed on the Recreation, Parks and Cultural Affairs agenda for discussion and review.
- B. A public hearing is required prior to forwarding the naming request to the full Common Council for approval. The hearing shall be held at a regular meeting of the Public Works Committee, and the scheduling of said hearing shall have been approved at a previous regular meeting by a majority vote of the Committee.
- C. A two-thirds-majority (10 votes) of the Common Council is required for the approval of all honorary or historic street names, except in the case where a living individual or a person who has been deceased less than one year is the honoree, in which case a two-thirds-majority plus one (11 votes) is required.

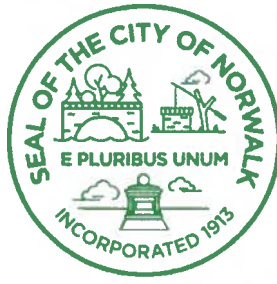

## Contract Staff Summary

<b>Department/Staff Contact</b>	Public Works Engineering/Paul Sotnik x47891
<b>City Council Committee</b>	Public Works Committee
<b>Date Approved by Committee</b>	
<b>Purpose/Scope</b>	Honorary Naming of a portion of West Avenue.
<b>Vendor</b> (Indicate if new or existing vendor)	N/A
<b>Term of Contract</b>	N/A
<b>Method of Procurement</b> (Indicate if sole source)	
<b>Cost of Contract</b>	
<b>Funding Source/Account Number</b>	
<b>Additional Information/Other Details</b>	Public Hearing – 2/3/2026



City of Norwalk  
Paul Sotnik, P.E.  
Senior Civil Engineer / Department of Engineering  
125 East Avenue  
Norwalk, CT 06856-5125  
Office Telephone: (203) 854-7891  
[www.norwalkct.gov](http://www.norwalkct.gov)  
E-Mail: [psotnik@norwalkct.gov](mailto:psotnik@norwalkct.gov)

## MEMORANDUM

**TO:** Vanessa Valadares, P.E. - Chief of Operations and Public Works

**FROM:** Paul L. Sotnik, P.E. - Senior Civil Engineer 

**CC:** James Meehan, P.E. - Principal Engineer

**REF:** Stanley Seligson Way  
Public Hearing and Action Item For the Honorary Naming of a portion of West Avenue

**DATE:** January 16, 2026

---

Mr. Michael Serrao and Ms. Jessica Potter delivered a request letter and package of supporting backup information concerning the above referenced topic to Mayor Rilling on October 29, 2025, requesting that the portion of West Avenue from Wall Street to Connecticut Avenue/Mathews Park be named Stanley Seligson Way in honor of his Redevelopment efforts, specifically in that area of West Avenue and his contributions to the City of Norwalk.

The proposed Honorary Street Name signs would be installed at the following locations. I have attached a map for reference.

- On West Avenue at the intersection of Wall Street.
- On West Avenue at the intersection Connecticut Avenue/Mathews Park.

On December 2, 2025 at their regularly scheduled meeting, the Public Works Committee of the City Council acknowledged the receipt of the request for the Honorary naming of the portion of West Avenue from Wall Street to Connecticut Avenue/Mathews Park to Stanley Seligson Way and called for the scheduling of a Public Hearing on Tuesday, February 3, 2026 at 7:15 P.M. concerning the topic in order to hear all parties interested in commenting on the proposed Honorary Street naming and to take such action on said naming that the Committee may deem advisable.

Therefore, I would like to request that the following Items be included on the agenda for the February 3, 2026 meeting of the Public Works Committee of the City Council for approval.

### Public Hearing

Conduct a Public Hearing to hear all parties interested in commenting on the proposed Honorary Street naming of the portion of West Avenue from Wall Street to Connecticut Avenue/Mathews Park to Stanley Seligson Way at 7:15 P.M.



City of Norwalk  
**Paul Sotnik, P.E.**  
**Senior Civil Engineer / Department of Engineering**  
125 East Avenue  
Norwalk, CT 06856-5125  
Office Telephone: (203) 854-7891  
[www.norwalkct.gov](http://www.norwalkct.gov)  
E-Mail: [psotnik@norwalkct.gov](mailto:psotnik@norwalkct.gov)

### New Business

Approve the Honorary naming of the portion of West Avenue from Wall Street to Connecticut Avenue/Mathews Park to Stanley Seligson Way.

I have attached a copy of Chapter 95 Streets and Sidewalks Article II Honorary and Historic Naming of Streets for reference.

If you have any questions, please do not hesitate to contact me.



CITY OF NORWALK  
**Harry W. Rilling**  
**Mayor**  
*hrilling@norwalkct.gov*  
p: 203-854-7294  
Norwalk City Hall  
125 East Avenue, PO Box 5125

Seligson Properties  
Norwalk, CT 06856  
605 West Avenue

December 1, 2025

Re: Request for Honorary Street Naming in Recognition of Stanley M. Seligson

Good afternoon, Seligson Properties,

It's my honor to support your proposal to recognize the legacy of Stanley M. Seligson through the City's honorary street naming program, by naming a portion of West Avenue "Stanley M. Seligson."

Stanley Seligson was born in Norwalk in 1933 and attended Norwalk schools. After becoming a successful real estate investor, he decided to give back to his community. In 1979, he formed Seligson Properties and, through his development work, helped transform the West Avenue section of Norwalk.

He was civic-minded and worked closely with the City of Norwalk on several public-private partnerships, including the City's "West Avenue Redevelopment Plan." This effort helped enhance the vibrancy of the West Avenue corridor.

As an active member of the community, he served as an advisor and board member to many Norwalk institutions, including the Greater Norwalk Chamber of Commerce, the Maritime Aquarium and the Lockwood-Mathews Mansion Museum, among others.

Given Mr. Seligson's deep connection to Norwalk and decades of contributions to this stretch of West Avenue, naming this portion of the street after him is an appropriate and meaningful way to honor his legacy.

Please don't hesitate to contact me if I can be of any assistance during this process.

A handwritten signature in black ink that reads "Harry W. Rilling". The signature is fluid and cursive.

Mayor Harry W. Rilling

605 West Avenue  
Norwalk, Connecticut 06850  
Phone: (203) 857-5600  
[www.seligsonproperties.com](http://www.seligsonproperties.com)



May 7, 2025

The Honorable Harry W. Rilling  
Mayor, City of Norwalk  
Norwalk City Hall  
125 East Avenue, PO Box 5125  
Norwalk, CT 06851  
*Via email:* [hrilling@norwalkct.org](mailto:hrilling@norwalkct.org)

**Re: Request for Honorary Street Naming in Recognition of Stanley M. Seligson;  
A portion of West Avenue, from Wall Street to Connecticut Avenue (Mathews Park)**

Dear Mayor Rilling,

Thank you again for taking the time to meet with me recently and for your support of our proposal to recognize the legacy of Stanley M. Seligson through the City's honorary street naming program.

On behalf of Seligson Properties, I respectfully request that a portion of West Avenue, specifically from the intersections of Wall Street (to the North) to Connecticut Avenue/Mathews Park (to the South), be designated in his honor. This stretch of West Avenue was a central focus of Mr. Seligson's professional efforts since the 1970's and includes an area subject to the City's "West Avenue Redevelopment Plan," a long-term initiative in which Mr. Seligson and our firm were proud to be active participants for more than a decade through a public-private partnership with the City of Norwalk.

Stanley M. Seligson was a visionary real estate investor, developer, and civic-minded business leader who played an instrumental role in shaping the West Avenue corridor and contributing to Norwalk's economic revitalization. Through investments in commercial properties, collaboration with city planners and agencies, and a commitment to the long-term success of the area, Mr. Seligson left an enduring mark on the City's landscape and business environment.

For your reference, we have enclosed a GIS parcel map highlighting the properties along West Avenue that Mr. Seligson and our firm currently own or have been historically associated with. These parcels reflect a sustained commitment to the corridor's improvement and continued vitality.

We believe that an honorary street naming would be a meaningful and appropriate way to recognize Mr. Seligson's decades of contributions to Norwalk and his deep connection to this important stretch of West Avenue. We welcome the opportunity to work with your office and the appropriate City bodies to move this forward and are happy to provide supporting documentation or attend any meetings necessary as part of the process. Thank you again for your consideration and support.

Sincerely,



Michael G. Serrao  
President & CEO

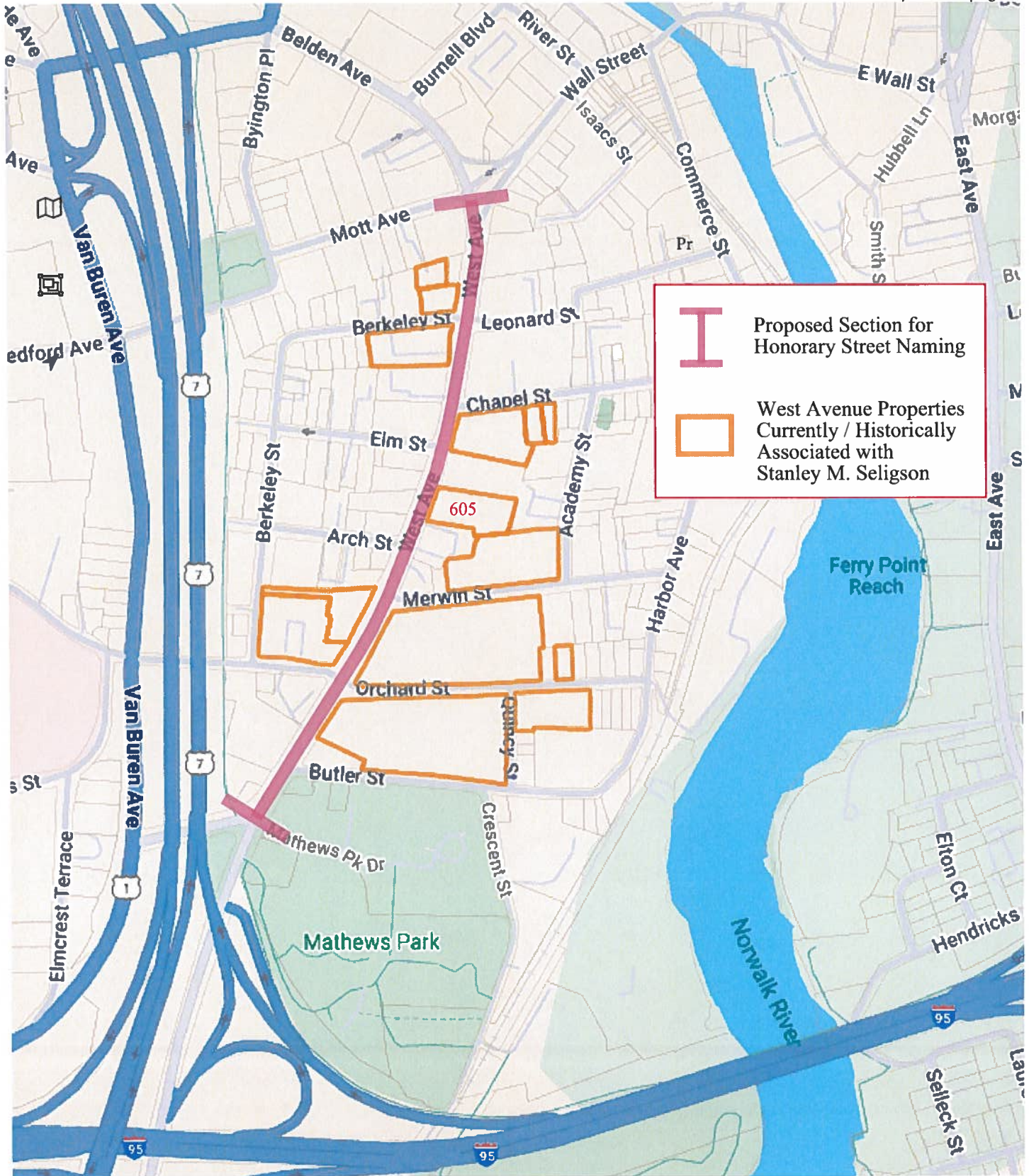



2019 AERIAL PHOTO DATA

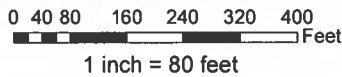

# STANLEY SELIGSON WAY

## Chapter 95. Streets and Sidewalks

### Article II. Honorary and Historic Naming of Streets

[Adopted 10-28-2014]

#### § 95-37. Purpose.

The purpose of this article is to establish guidelines and formalize procedures when considering the honorary or historic naming or renaming of a City-owned or controlled street or roadway, administered under the responsibility charged to the Public Works Committee of the Common Council.

#### § 95-38. Policy and considerations.

[Amended 4-14-2020]

If a City street or roadway is to be named in honor of an individual, it is generally required that such individual has made a significant contribution to the community through public service and deeds, and is respected for his or her accomplishments and good conduct. Consideration shall be given to individuals who have made recent accomplishments and contributions as well as individuals with historic ties to the City. An individual shall be deceased at least one year prior to the naming unless the Common Council determines by a two-thirds-majority plus one (11 votes) that a living individual or a person who has been deceased less than one year deserves the honor. Groups should not be in a position to influence the process by funding of past or future operations of the street or roadway, and it is ultimately important for the City to avoid any perception of improper manipulation, special favor, vested interest, or endorsement of businesses, products or services.

#### § 95-39. Procedure.

[Amended 4-14-2020]

Naming of City streets or roadways shall proceed as follows:

- A. The proposed naming of a City street or roadway shall be placed on a Public Works regular meeting agenda for discussion and review. In the event that the street or roadway to be named is located within a City park, the proposed naming shall be placed on the Recreation, Parks and Cultural Affairs agenda for discussion and review.
- B. A public hearing is required prior to forwarding the naming request to the full Common Council for approval. The hearing shall be held at a regular meeting of the Public Works Committee, and the scheduling of said hearing shall have been approved at a previous regular meeting by a majority vote of the Committee.
- C. A two-thirds-majority (10 votes) of the Common Council is required for the approval of all honorary or historic street names, except in the case where a living individual or a person who has been deceased less than one year is the honoree, in which case a two-thirds-majority plus one (11 votes) is required.

**CITY OF NORWALK  
PUBLIC WORKS COMMITTEE  
REGULAR MEETING  
DECEMBER 2, 2025  
BY ZOOM VIRTUAL MEETING**

To allow public access, anyone may access a meeting by telephone and/or Zoom, or a recording in the City of Norwalk YouTube channel. Specific instructions and links can be found at [norwalkct.gov/meetings](http://norwalkct.gov/meetings).

Members of the public may call in to participate. Callers will not be able to see the meeting participants. All participants will be muted upon entering the meeting. To speak, dial \*9 on the phone and you will be called on by the host of the meeting during the public comment section. All speakers must state their name and address. Comments must be on a topic on the agenda, and are limited to three minutes. Anyone disrupting the orderly conduct of the meeting, including by using threatening, hateful, or sexually-explicit language, will be removed. Please find the information using the link above.

Members of the public who wish to provide "live comments" may also use the Zoom meeting platform. All participants will be muted upon entering the meeting. To speak, click the "raise your hand indicator" and you will be called by the host of the meeting during the public comment section. All speakers must state their name and address. Comments must be on a topic on the agenda, and are limited to three minutes. Anyone disrupting the orderly conduct of the meeting, including by using threatening, hateful, or sexually-explicit language, will be removed. Please find the information using the link above.

Members of the public who wish to provide public comment are encouraged to submit those via email in advance of the meeting. For these comments to be included into the record, they must be submitted by 12:00 p.m. the day of the meeting. Please email Monique Cipriano at [mcipriano@norwalkct.gov](mailto:mcipriano@norwalkct.gov) with the subject line "Public Comment" to provide written public comment prior to the meeting.

**I. CALL TO ORDER**

Chairman Frayer called the meeting to order at 7:01p.m.

**II. ROLL CALL**

Chairman Frayer called the Roll: James Frayer, Barbara Smyth, Anne Wennerstrand, Heather Dunn, Darlene Young (7:12p.m.)

At Roll Call there were four (4) Committee members present, constituting a quorum present. Darlene Young arrived at 7:12p.m. Dajuan Wiggins and Nora Niedzielski-Eichner were absent.

**ATTENDANCE:** James Frayer, Chairman; Barbara Smyth; Anne Wennerstrand; Heather Dunn; Darlene Young (7:12p.m.)

**STAFF:** Vanessa Valadares, Chief of Operations and Public Works; James Meehan,

Principal Engineer; Chris Torre, Superintendent of Operations, Thomas Szabo, Waste Programs Manager; Wilber Giron, Permit Engineer; Paul Sotnik, Senior Civil Engineer; Brian Candela, Asst Corp Counsel; Nicole Eady

**III. ACCEPTANCE OF MINUTES**

**A. REGULAR MEETING: OCTOBER 7, 2025**

There was no report on this item.

**\*\*MS. SMYTH MOVED THE ITEM**

**\*\*MOTION PASSED UNANIMOUSLY**

**IV. PUBLIC PARTICIPATION**

**Pamela Meskunas of 39 Lockwood Lane:** Extended her appreciation to Mayor Elect Barbara Smyth and the DPW for including a status update of the Lockwood Lane sidewalk. She stated that the residents unanimously opposed the sidewalk at the public information meeting in October. She said they diligently submitted their feedback on the proposal by the deadline and are eagerly waiting for information about next steps and specifically a follow-up meeting. They want to know how and when the residents will be notified about the meeting. An exception request form was requested, and they were told it is premature, but they would still like to do that. She also stated they want to know what measures are being taken to address drainage problems as some of the residents are having issues. She said the residents should be given assurances that the drainage project is both effective and complete. She has also asked that the drain in front of her property that was moved to accommodate the sidewalk be moved back to its previous location where the rainwater is collecting.

**Katie Restrepo of 15 Fairfield Terrace:** She spoke in favor of the honorary street naming from Lincoln Avenue Extension to Master Chief Alexander Restrepo Way. She said he was a Brien McMahon Graduate, state champion wrestler, one of the longest serving Navy Seals. The flag has flown over the Capitol twice for his acts of bravery. He was hand selected to be on the first SEAL team six. She hopes to have another opportunity to name all of his acts of valor and the way he served the country.

**Michael Serrao of Seligson Properties:** President and CEO of Seligson Properties with offices for over 22 years, located at 605 West Avenue. He is in favor of the honorary naming of a portion of West Avenue. He said that Stanley Seligson was born in 1933 in Norwalk. Since the early 1950's Mr. Seligson continuously operated his various businesses headquartered in downtown Norwalk. He spent more than 60 years investing in Norwalk. He spent several decades specifically helping to shape and revitalize the West Avenue corridor. Mr. Serrao gave a brief background to all of Mr.

City of Norwalk  
Public Works Committee  
Regular Meeting  
December 2, 2025  
By Zoom Virtual Meeting  
Page 2

Seligson's property. There are letters of support from Mayor Harry Rilling and several other prominent members of Norwalk.

**Michelle Petrides** speaking on behalf of Charlie Restrepo. She initiated the petition for the street sign. She supports the naming and asks to make an addendum to the street name from Lexington Extension to Lincoln Avenue Extension.

**Lee-Ann Etter of 18 Lockwood Lane:** She strongly opposes the changes to their neighborhood. They do not want sidewalks. She is interested in the city's broad approach to city tree removals and plantings. She asked about the tree of heaven.

**Jack Meskunas of 39 Lockwood Lane:** He asked when they were going to abandon putting in an unwanted sidewalk on Lockwood Lane. He said the drainage project that has been going on for the past 17 years hasn't solved the problem. Now the new project is really a sidewalk project with drainage as an ancillary part of it because all the drains on Lockwood Lane were moved to accommodate the placement of a sidewalk such as the one in front of his house. He stated that none of the residents want a sidewalk and that should be the end of it. He said they are not there to be heard, they are there to be addressed and for the project to be cancelled. There is only a certain amount of money in the city budget that can be used for various projects. Why would you rip up Lockwood Lane, a street that goes nowhere to build a commercial sidewalk when the city should use that money somewhere else where it is needed. He gave an example of a school in need. He gave more details about the drains being moved.

**Rick Controlini of 28 Lockwood Lane:** He would like to know why they need a sidewalk. And he would like someone to answer that question.

**Betsey Ward of 22 Lockwood Lane:** She would like to know how this gets resolved. She wants to know the process and what happens next.

Chairman Frayer closed public participation at 7:24p.m.

## **V. NEW BUSINESS**

### **A. ACKNOWLEDGE THE RECEIPT FOR THE HONORARY NAMING OF LEXINGTON AVENUE EXTENSION TO MASTER CHIEF ALEXANDER RESTREPO WAY.**

Chairman Frayer read Item A and Item B together.

The Committee began a discussion to cancel the January 6, 2026 meeting due to staff changes. All parties will be notified that the meeting has been cancelled, and the next scheduled meeting will be held on February 3, 2026.

Mr. Sotnik stated they received a letter from Ms. Petridis back in October requesting that this item be moved forward. The sign, if approved, would be put in at the Lincoln Avenue Extension area. Mr. Sotnik explained the process for honorary street naming.

**\*\*MS. SMYTH MOVED THE ITEM STREET NAME CORRECTION  
\*\*MOTION PASSED UNANIMOUSLY**

**B. SCHEDULE A PUBLIC HEARING FOR THE HONORARY NAMING OF LEXINGTON AVENUE EXTENSION TO MASTER CHIEF ALEXANDER RESTREPO WAY. THE PUBLIC HEARING SHALL BE CONDUCTED IN ORDER TO HEAR ALL PARTIES INTERESTED IN COMMENTING ON THE PROPOSED HONORARY STREET NAMING AND TO TAKE SUCH ACTION ON SAID NAMING THAT THE COMMITTEE MAY DEEM ADVISABLE. THE PUBLIC HEARING IS SCHEDULED FOR TUESDAY, JANUARY 6, 2026 AT 7:00 P.M. BY WAY OF VIDEOCONFERENCE/TELECONFERENCE.**

Chairman Frayer read Item A and Item B together.

The Committee began a discussion to cancel the January 6, 2026 meeting due to staff changes. All parties will be notified that the meeting has been cancelled, and the next scheduled meeting will be held on February 3, 2026.

Mr. Sotnik stated they received a letter from Ms. Petridis back in October requesting that this item be moved forward. The sign, if approved, would be put in at the Lincoln Avenue Extension area. Mr. Sotnik explained the process for honorary street naming.

**\*\*MS. SMYTH MOVED THE ITEM STREET NAME CORRECTION  
\*\*MOTION PASSED UNANIMOUSLY**

**C. ACKNOWLEDGE THE RECEIPT FOR THE HONORARY NAMING OF A PORTION OF WEST AVENUE FROM WALL STREET TO CONNECTICUT AVENUE/MATHEWS PARK TO STANLEY SELIGSON WAY.**

Chairman Frayer read Item C and Item D together.

**\*\*MS. WENNERSTRAND MOVED THE ITEM  
\*\*MS. YOUNG AND MS. DUNN OPPOSED  
\*\*MOTION PASSED FOUR TO TWO**

**D. SCHEDULE A PUBLIC HEARING FOR THE HONORARY NAMING OF A PORTION OF WEST AVENUE FROM WALL STREET TO CONNECTICUT AVENUE/MATHEWS PARK TO STANLEY SELIGSON WAY. THE PUBLIC HEARING SHALL BE CONDUCTED IN ORDER TO HEAR ALL PARTIES INTERESTED IN COMMENTING ON THE PROPOSED HONORARY STREET NAMING AND TO TAKE SUCH ACTION ON SAID NAMING THAT THE COMMITTEE MAY DEEM ADVISABLE. THE PUBLIC HEARING IS SCHEDULED FOR TUESDAY, JANUARY 6, 2026 AT 7:00 P.M. BY WAY OF VIDEOCONFERENCE/TELECONFERENCE.**

Chairman Frayer read Item C and Item D together.

**\*\*MS. WENNERSTRAND MOVED THE ITEM**

**\*\*MS. YOUNG AND MS. DUNN OPPOSED**

**\*\*MOTION PASSED FOUR TO TWO**

**E. AUTHORIZE THE ACCEPTANCE OF A SIDEWALK EASEMENT IN FAVOR OF THE CITY AT 467 CONNECTICUT AVENUE.**

Mr. Giron reported that DPW required the developer to build a new sidewalk to improve pedestrian access and safety. Some portions of that new sidewalk extended outside of the public right-of-way and onto private property. Because of that, the city needs a permanent sidewalk easement that the public could continue to use. DPW staff, Corporation Counsel and Toll Brothers worked together to finalize the easement language and survey map. Mr. Giron shared his screen, so the committee could see the survey that outlined the boundaries. This is at the corner of West Avenue and Butler. It is also adjacent to Orchard and Quincy Street. The easement gives the public permanent access to pedestrians, sets maintenance responsibilities and allows the city to install signs and/or traffic equipment. He explained the map and answered all questions the committee had.

**\*\*MS. WENNERSTRAND MOVED THE ITEM**

**\*\*MOTION PASSED UNANIMOUSLY**

**F. BURNS CONSTRUCTION PM2024-2 PERMANENT PAVEMENT REPAIRS AND SURFACE RESTORATION**

**1. AUTHORIZE MAYOR HARRY W. RILLING TO EXECUTE THE SECOND AMENDMENT TO THE APRIL 9, 2024, AGREEMENT BETWEEN THE CITY OF NORWALK AND BURNS CONSTRUCTION COMPANY, INC., FOR PROJECT PM2024-2 – PERMANENT ROADWAY REPAIRS AND SURFACE RESTORATION, FOR AN AMOUNT NOT TO EXCEED \$525,000.00**  
**ACCOUNT NO. 03 00 00 2602**

**2. AUTHORIZE THE CHIEF OF OPERATIONS AND PUBLIC WORKS, TO EXECUTE ORDERS ON CONTRACT WITH BURNS CONSTRUCTION COMPANY, INC., FOR PROJECT PM2024-2 PERMANENT PAVEMENT REPAIRS AND SURFACE RESTORATION, FOR AN AMOUNT NOT TO EXCEED \$52,500.00.**  
**ACCOUNT NO. 03 00 00 2602**

Chairman Frayer read Item F1 and Item F2 together.

Mr. Giron reported that DPW has the option to extend the contract for two additional one-year terms. They have exercised the first extension which carried them through 2025, and they would now like to request the final extension. The funding for that is for

trenches that were measured through October and includes projected excavations expected for the remainder of the year. The work on this contract is fully funded through the road restoration fees collected through the city's permit process.

**\*\*MS. SMYTH MOVED THE ITEM**

**\*\*MOTION PASSED UNANIMOUSLY**

**G. AUTHORIZE THE MAYOR, HARRY W. RILLING, TO EXECUTE A THIRD AMENDMENT TO THE APRIL 12, 2021, AGREEMENT FOR HOUSEHOLD HAZARDOUS WASTE COLLECTION BETWEEN THE CITY OF NORWALK AND CLEAN HARBORS ENVIRONMENTAL SERVICES INC. PROJECT 4079 FOR AN AMOUNT NOT TO EXCEED \$68.86 PER HOUSEHOLD AND \$41.20 PER ½ HOUSEHOLD.**

**ACCOUNT NO. 01 40 42 5258**

Mr. Szabo reported that this is for their annual household hazardous waste collection event. They usually receive approximately 400 residents per year. Clean Harbor has always been a reliable vendor for them. They also partner with five (5) different municipalities for competitive pricing. He explained the process of organizing the dates for the event and informing residents through social media and online posting. He stated that the event begins in April to September and occurs once a month.

**\*\*MS. SMYTH MOVED THE ITEM**

**\*\*MOTION PASSED UNANIMOUSLY**

**H. AUTHORIZE THE PURCHASING AGENT TO ISSUE A PURCHASE ORDER WITH MORTON SALT INC. (STATE CONTRACT# 24PSX0150) FOR ROAD SALT FOR A SUM NOT TO EXCEED \$81.24/TON FOR THE 2025-26 WINTER SEASON.**

**ACCOUNT NO. 580000 5796 AID03**

Mr. Torre explained the process of purchasing the salt. They receive almost a \$30 savings. He said that this is rock salt. . This salt will be received from a gateway terminal in New Haven. The committee began a discussion about pricing. The prices are based on State contract prices.

**\*\*MS. YOUNG MOVED THE ITEM**

**\*\*MR. FRAYER ABSTAINED**

**\*\*MOTION PASSED WITH ONE ABSTENTION**

**I. AUTHORIZE THE PURCHASING AGENT TO ISSUE A PURCHASE ORDER WITH CARGILL, INC. (STATE CONTRACT# 24PSX0150) FOR ROAD SALT FOR A SUM NOT TO EXCEED \$81.24/TON FOR THE 2025-26 WINTER SEASON.**

**ACCOUNT NO. 580000 5796 AID03**

Mr. Torre explained the process of purchasing the salt. They receive almost a \$30 savings. He said that this is rock salt. . This salt will be received from a gateway terminal in New Haven. The committee began a discussion about pricing. The prices

are based on State contract prices.

**\*\*MS. YOUNG MOVED THE ITEM**

**\*\*MR. FRAYER ABSTAINED**

**\*\*MOTION PASSED WITH ONE ABSTENTION**

**J. AUTHORIZE THE MAYOR, HARRY W. RILLING, TO EXECUTE A 3RD AMENDMENT TO THE JULY 20TH, 2023 AGREEMENT BETWEEN THE CITY OF NORWALK AND CDM SMITH INC., FOR PROJECT NOS. 4240 AND 4240A, DRG2023-2 ENGINEERING DESIGN SERVICES FOR MUNICIPAL SEPARATE STORM SEWER SYSTEMS, FOR A SUM NOT TO EXCEED \$232,580.00.**

**ACCOUNT NO. 09 19 4027 5777 C0425**

**09 24 4027 5777 C0425**

**09 25 4027 5777 C0425**

**09 26 4027 5777 C0425**

**09 24 4021 5777 C0440**

**09 25 4021 5777 C0440**

Ms. Valadares reported that they engaged CDM Smith to assist with the MS4 application approximately three (3) years ago. Every year they must reapply for the permit and maintain compliance. The request for the extension is for the renewal of the permit in the spring and so they continue to maintain compliance as well. She explained the process to the committee.

**\*\*MS. WENNERSTRAND MOVED THE ITEM**

**\*\*MOTION PASSED UNANIMOUSLY**

**K. AUTHORIZE THE MAYOR TO EXECUTE BETTSWOOD ROAD AND BARBARA DRIVE DRAINAGE IMPROVEMENTS AND SEWER SEPARATION GRANT AND ANY AND ALL OTHER AGREEMENTS AND OTHER DOCUMENTS NECESSARY TO EFFECTUATE THE GRANT.**

Ms. Valadares reported that they received the grant about a year and a half ago. They focused this grant on Bettswood and Barbara Drive for drainage improvements. She explained the grant. She said they may break ground this spring. The construction costs may come to about 3.1 million dollars and the grant would cover \$950,000.00 of that cost.

**\*\*MS. DUNN MOVED THE ITEM**

**\*\*MOTION PASSED UNANIMOUSLY**

## **VI. REPORTS**

### **A. TREE OPERATIONS AND PROGRAMMING**

City of Norwalk

Public Works Committee

Regular Meeting

December 2, 2025

By Zoom Virtual Meeting

Page 7

Mr. Torre reported that they do replant trees. He said if there are any concerns about the Tree of Heaven, he urged the residents to call customer service. They only take down trees in the city's right-of-way. They replant trees whenever they can and he explained that process. Mr. Sotnik reported that in this past year they have planted over 300 trees. Location can be an issue for tree planting. Ms. Valadares explained the ordinance of replacing trees to the committee. The committee began to discuss the history of tree planting. Mr. Torre said they are moving forward with their master plan and they are always going to plant more trees than they remove. They talked about more tree planting in the South Norwalk area.

#### **B. MONTHLY SOLID WASTE REPORT**

Mr. Szabo reported that the number change could be due to the changes in garbage collection and recycling. They discussed the percentages.

#### **C. FOOD SCRAP DROP-OFF REPORT**

Mr. Szabo reported they have been putting in more effort into education and outreach. Posting on social media and getting out in the public. He talked about ways to do so.

#### **D. ONGOING PROJECTS STATUS**

##### **1. ROADWAY PAVING AND SIDEWALK INSTALLATION FOR LOCKWOOD LANE AND HEATHER LANE AREA**

Ms. Valadares reported that on October 15, 2025 there was a public information session for the neighborhood to present the drawings that their consultant Tighe & Bond prepared for the proposed sidewalk for Lockwood, Heather Lane and some of the other small streets. Those streets are part of the drainage project and there is a forecast for paving. They want to go back and pave the road and follow the complete street ordinance, to do so they are proposing adding sidewalks to those streets. All of the residents had an opportunity to send comments to them by October 31, 2025. They compiled all the comments received by the first week of November with the consultant. They are now reviewing those comments to see what they can do with the design. They are expecting feedback very soon. Once they receive the design, they will schedule another public information session with what the new proposed design will be and try to address the concerns.

Mr. Candella stated that all city projects shall apply to the complete streets design guide to all transportation projects within the city unless they may be exempted under 33A7 or accepted under 33A. He went over the exemptions and exceptions with the committee and went through steps. The committee began a brief discussion about what the ordinance states and how to address the needs and concerns of the residents if they don't want the sidewalks. Mr. Candella said that besides talking to your elected official

or coming to public meetings, residents can voice their opinion by filing an exception report or claim an exemption under these projects, under the ordinance. Committee members expressed their concern of how to engage residents long before projects start and improving the communication as well.

## **2. UPDATE STATUS ON CONSTRUCTION PROJECTS**

Mr. Meehan reported they have completed sidewalks and paving installation on Flax Hill Road and Highland Avenue to Arbor Drive. Still working on Arbor Drive to Washington Street. Lockwood and Heather drainage have been done, finishing all the patchwork. There are minor punch list items. Grumman Ave is complete besides one small area. There will be test pit work on Rowayton Avenue coming up. West Cedar Street Bridge is now complete. The ribbon cutting is being held on Friday. He said Lexington Avenue doesn't have right-of-entry, but they are trying to acquire that now so they could do the work.

## **VII. DISCUSSION**

There was no report for this item.

## **VIII. ADJOURNMENT**

Ms. Smyth moved to adjourn.  
Motion passed unanimously.  
The meeting was adjourned at 9.12p.m.

## **UPCOMING MEETINGS**

**TUESDAY, FEBRUARY 3, 2026  
PUBLIC WORKS COMMITTEE  
7:00 P.M. PUBLIC HEARING FOLLOWED  
BY REGULAR MEETING BY WAY OF VIDEOCONFERENCE/TELECONFERENCE**

**Memorandum**

To: Mayor Barbara Smyth  
Members of the Common Council

From: Darin L. Callahan, Assistant Corporation Counsel

Cc: Mario Coppola, Corporation Counsel  
Vanessa Valadares, Chief of Operations and Public Works

Date: December 5, 2025

Re: Request by Housing Authority of The City of Norwalk concerning the City of  
Norwalk's Easement at 20 Day Street

.....

Housing Authority of The City of Norwalk (the "Authority"), in accordance with Section 22a-133o of the Connecticut General Statutes ("C.G.S."), has applied for an Environmental Land Use Restriction ("ELUR") upon land it owns at 20 Day Street, Norwalk, CT ("Subject Property") as a mechanism for complying with environmental laws in lieu of other abatement activities. In order for the Authority to satisfy the statutory and regulatory requirements for issuance of an ELUR by the Department of Energy and Environmental Protection ("DEEP"), the Authority must first obtain a subordination agreement<sup>1</sup> from any and all encumbrancers (e.g. - easement holders) holding an interest in the Subject Property.

(b) (1) No owner of land may record an environmental land use restriction on the land records of the municipality in which such land is located unless he simultaneously records documents which demonstrate that each person holding an interest in such land or any part thereof, including without limitation each mortgagee, lessee, lienor and encumbrancer, irrevocably subordinates such interest to the environmental land use restriction, provided the commissioner may waive such requirement if he finds that the interest in such land is so minor as to be unaffected by the environmental land use restriction. The commissioner shall waive the requirement to obtain subordination agreements for any interest in land that, when acted upon, is not capable of creating a condition contrary to any purpose of such environmental land use restriction. An environmental land use restriction shall run with land, shall bind the owner of the land and his successors and assigns, and shall be enforceable notwithstanding lack of privity of estate or contract or benefit to particular land.

Conn. Gen. Stat. § 22a-1330(b)(1).

---

<sup>1</sup> A subordination agreement is an agreement to alter the natural priority of interests in land such that a prior-in-right interest holder's interest in land becomes subject to a subsequent-in-right interest holders interest in land by an agreement commonly referred to as a "subordination agreement."

The City of Norwalk ("City") holds sidewalk easements upon, over and under the Subject Property.

I, in coordination with the Public Works Department (Vanessa Valadares), have worked with the Authority's representatives to address the request. Subject to required public approvals, the Parties appears to generally be in agreement that the form and substance of subject Subordination Agreement.

Based on the forgoing, we are recommending the following:

**AUTHORIZE THE MAYOR, BARBARA SMYTH TO ENTER INTO A SUBORDINATION AGREEMENT AND SUCH OTHER INSTRUMENTS INCIDENTAL THERETO WITH THE HOUSING AUTHORITY ("NHA") FOR THE CITY OF NORWALK WITH RESPECT TO THE CITY'S EASEMENTS AT 20 DY STREET IN CONNECTION WITH NHA's ELUR APPLICATION TO DEEP.**

SUBORDINATION AGREEMENT  
20 Day Street, Norwalk, CT

The CITY OF NORWALK, a municipal corporation located in the County of Fairfield, State of Connecticut, having a principal office in Norwalk, Connecticut (the "City"), is a holder of sidewalk easements pursuant easement dated \_\_\_\_\_, 2025 recorded in Volume \_\_\_\_, Page \_\_\_\_ of the Norwalk Land Records ("Easements").

HOUSING AUTHORITY OF THE CITY OF NORWALK, a public body corporate and politic organized and existing pursuant to Section 8-40 of the Connecticut General Statutes with a principal place of business located at 24 ½ Monroe Street, Norwalk, CT 06854 ("Land Owner") is the owner of the real property and improvements known as 20 Day Street, Norwalk, Connecticut (the "Property"), which Property is subject to, and burdened by, the Easements.

The City has been advised that the Land Owner will be granting to the Commissioner of the Energy and Environmental Protection of the State of Connecticut ("DEEP") a Declaration of Environmental Land Use Restriction and Grant of Easement (the "Grant") encumbering the Property to be recorded in the Norwalk Land Records. The City agrees for itself, its successors and assigns, in consideration of the Land Owner's agreements in this Subordination Agreement, that subject to the other terms and conditions in this Subordination Agreement, the Easements are hereby modified to make the Easements automatically and irrevocably subordinate to said Grant and to the rights, covenants, restrictions and easements created by and under said Grant (collectively, the "Grant Interest"), but only with respect to that portion, if any, of the area of the Easements which is actually located within the Subject Area (as defined and described in the Grant) so that the City agrees to be bound by and to comply with the provisions of the Grant subject to the terms and conditions set forth herein, notwithstanding that the Easements were recorded prior to the Grant or this Subordination Agreement. After recording the Grant and this Subordination Agreement, Land Owner agrees to provide copies of the recorded documents to the City and note the volume and page numbers in the spaces below and return same to the City.

Notwithstanding anything to the contrary contained in this Subordination Agreement, the Land Owner, on its behalf and on behalf of its successors and assigns, acknowledges and agrees, as a covenant on and against the Property running with the Property, that this agreement by the City to subordinate its Easements to the Grant is further conditioned upon the following: (1) that any expense incurred by the City as a result of compliance with the Grant, the Grant Interests or with this Subordination Agreement or otherwise in connection with this Subordination Agreement (including but not limited to any expenses incurred by the City in the enforcement of, or interpretation of, this Subordination Agreement) or as a consequence of the Easements being subordinate to the Grant and the Grant Interests, shall be borne entirely by the Land Owner, its successors and assigns, and shall be due and payable from same to the City immediately upon demand by the City; and (2) that the Land Owner, its successors and assigns, each agrees to defend, indemnify, reimburse and hold harmless the City from and against any and all costs, expenses, fees (including but not limited to attorneys', consultant and expert fees), liabilities, penalties, fines, claims, losses, obligations, orders, suits or damages (collectively, "Costs") arising out of, or in connection, with (i) the Grant, (ii) the Grant Interests, (iii) this Subordination Agreement, and (iv)

any and all environmental conditions present in, on or under the Property unless such Costs are solely caused by the City's intentional misconduct.

Prior to the execution of this Subordination Agreement, Land Owner shall provide to the City a copy of the ELUR Application submitted to DEEP including copies of environmental reports regarding the nature and extent of contamination of soils at the Property. In the event of an unforeseen combination of circumstances or the resulting state that calls for immediate action to prevent a significant risk to human health or the environment, the destruction of property or the disruption of public utility service which would require disturbing the soil at the Property, the City shall notify Land Owner of such emergency and that such risk cannot be abated without suspending the Grant and Land Owner shall immediately notify DEEP of the emergency, advise of the suspension of the Grant due to such emergency and follow the requirements of DEEP including, without limitation, the following: Land Owner shall take all action necessary to limit both the extent and duration of the suspension of the Grant to the minimum reasonably necessary to adequately respond to the emergency; implement all measures necessary to limit actual and potential present and future risk to human health and the environment resulting from such suspension; and after the emergency is abated, implement a plan approved in writing by DEEP on a schedule approved by DEEP, to ensure that the Subject Area of the Grant is remediated in accordance with Sections 22a-133k-1 to 22a-133k-3, inclusive, of the Regulations of Connecticut State Agencies and restored to the condition described in the Grant. In the event of such emergency Land Owner shall provide the City with access to other property of Land Owner outside the Easements reasonably close to the Easements to permit the City to perform such emergency activities without disturbing soil within the Grant or limiting the extent and duration of such disturbance of soil causing the emergency suspension of the Grant.

Land Owner, on its behalf and that of its successors and assigns, further acknowledges and agrees that nothing contained in this Subordination Agreement shall affect any other easement or easement right that the City may hold including any that involve Land Owner property.

Notwithstanding anything to the contrary contained in this Subordination Agreement, if the Land Owner fails to timely perform any obligation imposed on the Land Owner under this Subordination Agreement within thirty (30) days of Land Owner's receipt of a written notice of default from DEEP or the City (including but not limited to the Land Owner's obligation hereunder to timely reimburse and indemnify the City from any Costs) and if Land Owner has not cured such default or has no valid defense to the alleged default which Land Owner has asserted and is pursuing, within said 30-day period, then Land Owner agrees that any time after the expiration of said 30-day cure period the City has the right to seek whatever remedy may be available to the City either in law or equity, as well as to recover from Land Owner the City's reasonable costs and expenses of enforcing Land Owner's obligations under this Subordination Agreement (including but not limited to attorneys', consultants, and expert fees incurred by the City).

All notices required or permitted hereunder shall be sent via certified mail return receipt requested or nationally recognized overnight courier service as follows, provided that if Land Owner is no longer the owner of the Property then The City shall be entitled to send such notice to the then current owner of the Property using the address for said current owner provided by the tax assessor of the municipality in which the Land is located:

To City of Norwalk:

City of Norwalk, Law Department  
125 East Avenue, Norwalk, CT 06851  
Attn: Corporation Counsel

With Copy to:

City of Norwalk, Dept. of Public Works  
125 East Avenue, Norwalk, CT 06851  
Attn: Chief of Operations and Public Works

City of Norwalk, Mayor's Office  
125 East Avenue, Norwalk, CT 06851  
Attn: Harry W. Rilling

To Land Owner:

Housing Authority of the City of Norwalk  
24 ½ Monroe Street, Norwalk, CT 06854  
Attn: Adam Bovilsky

With Copy to:

Lattarulo Law Firm, LLC  
304 Main Street #329, Norwalk, CT 06851  
Attn: Donna Rattarulo

Land Owner understands, acknowledges and agrees that this Subordination Agreement is being provided by the City without any representations, covenants or warranties of any kind.

The covenants and obligations imposed on the Land Owner in this instrument shall be covenants and obligations that run with the land and are binding on the Land Owner, its successors and assigns, and inure to the benefit of the City, its successors and assigns.

This Subordination Agreement is governed by the laws of the State of Connecticut without resort to any conflict of law principals that would result in the application of the law of any state other than the State of Connecticut.

**[SIGNATURE PAGES FOLLOWS]**





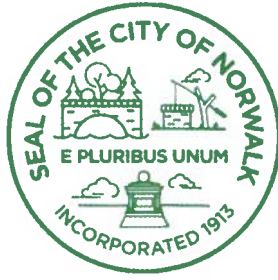

## Contract Staff Summary

<b>Department/Staff Contact</b>	DPW Engineering / Paul Sotnik x47891
<b>Common Council Committee</b>	Public Works Committee
<b>Date Approved by Committee</b>	
<b>Purpose/Scope</b>	Honorary Naming of Lincoln Avenue Extension to Master Chief Alexander Restrepo Way
<b>Vendor</b> (Indicate if new or existing vendor)	N/A
<b>Term of Contract</b>	
<b>Method of Procurement</b> (Indicate if sole source)	
<b>Cost of Contract</b>	
<b>Funding Source/Account Number</b>	
<b>Additional Information/Other Details</b>	Public Hearing 2/3/2026



City of Norwalk  
Paul Sotnik, P.E.  
*Senior Civil Engineer / Department of Engineering*  
125 East Avenue  
Norwalk, CT 06856-5125  
Office Telephone: (203) 854-7891  
[www.norwalkct.gov](http://www.norwalkct.gov)  
E-Mail: [psotnik@norwalkct.gov](mailto:psotnik@norwalkct.gov)

## MEMORANDUM

**TO:** Vanessa Valadares, P.E. - Chief of Operations and Public Works

**FROM:** Paul L. Sotnik, P.E. - Senior Civil Engineer 

**CC:** James Meehan, P.E. - Principal Engineer

**REF:** Master Chief Alexander Restrepo Way  
Public Hearing and Action Item For the Honorary Naming of Lincoln Avenue Extension

**DATE:** January 16, 2026

---

Ms. Michelle Petrides delivered a request letter and package of supporting backup information concerning the above referenced topic on October 9, 2025, requesting that Lincoln Avenue Extension be named Master Chief Alexander Restrepo Way in honor of his military service in the United States Navy in Seal Team SIX as a Master Chief.

The proposed Honorary Street Name sign would be installed at the following location. I have attached a map for reference.

- On Lincoln Avenue Extension at the intersection of Lowndes Avenue.

On December 2, 2025 at their regularly scheduled meeting, the Public Works Committee of the City Council acknowledged the receipt of the request for the Honorary naming of Lincoln Avenue Extension to Master Chief Alexander Restrepo Way and called for the scheduling of a Public Hearing on Tuesday, February 3, 2026 at 7:00 P.M. concerning the topic in order to hear all parties interested in commenting on the proposed Honorary Street naming and to take such action on said naming that the Committee may deem advisable.

Therefore, I would like to request that the following Items be included on the agenda for the February 3, 2026 meeting of the Public Works Committee of the City Council for approval.

### Public Hearing

Conduct a Public Hearing to hear all parties interested in commenting on the proposed Honorary Street naming of Lincoln Avenue Extension to Master Chief Alexander Restrepo Way at 7:00 P.M.



**DEPARTMENT OF  
ENGINEERING**

City of Norwalk  
**Paul Sotnik, P.E.**  
**Senior Civil Engineer / Department of Engineering**  
125 East Avenue  
Norwalk, CT 06856-5125  
Office Telephone: (203) 854-7891  
[www.norwalkct.gov](http://www.norwalkct.gov)  
E-Mail: [psotnik@norwalkct.gov](mailto:psotnik@norwalkct.gov)

New Business

Approve the Honorary naming of Lincoln Avenue Extension to Master Chief Alexander Restrepo Way.

I have attached a copy of Chapter 95 Streets and Sidewalks Article II Honorary and Historic Naming of Streets for reference.

If you have any questions, please do not hesitate to contact me.

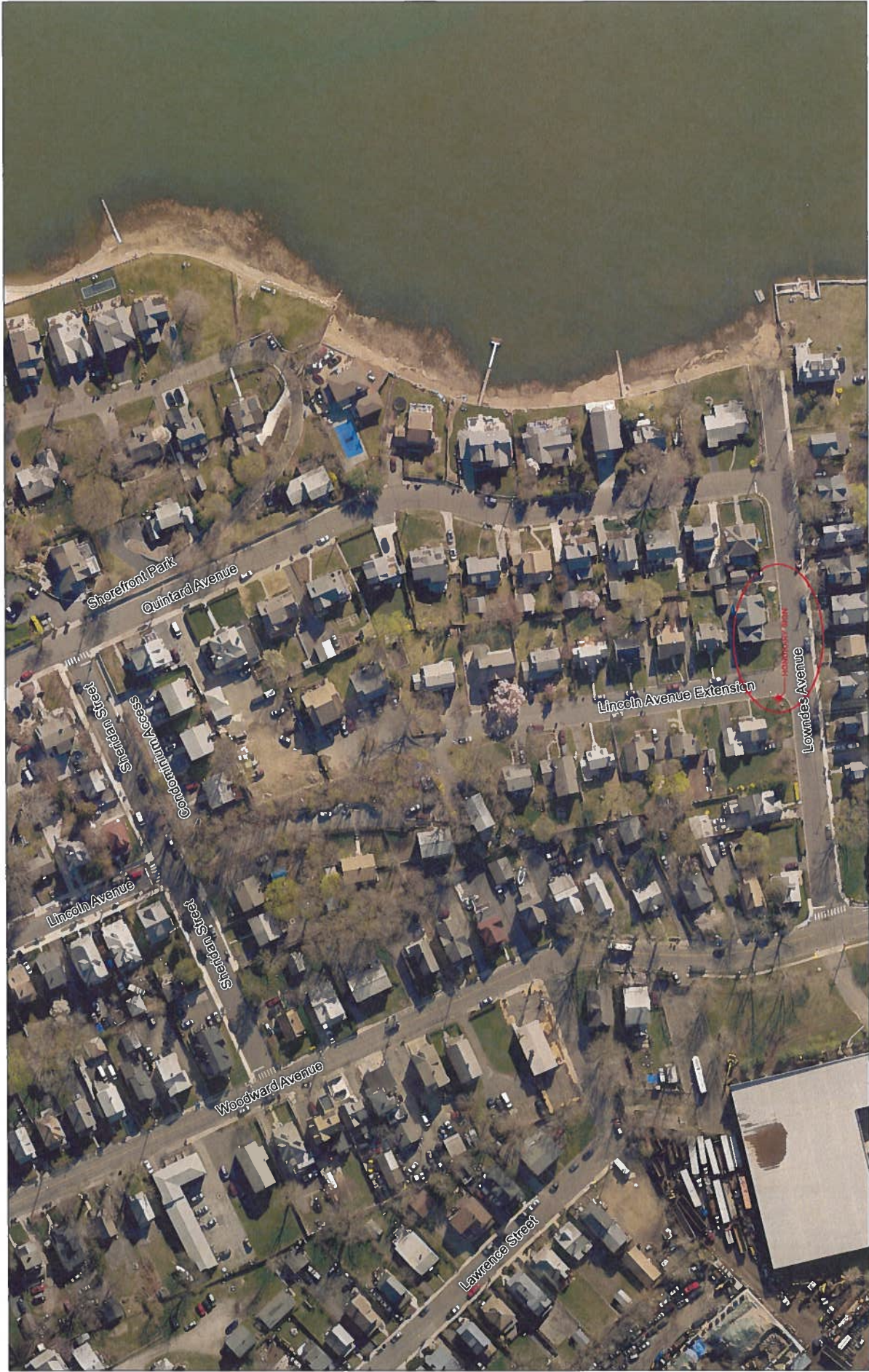

MASTER CHIEF ALEXANDER RESTREPO WAY

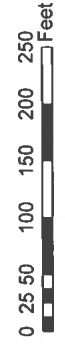

1 inch = 50 feet

2019 AERIAL PHOTO DATA



Michelle Petrides  
194 East Avenue  
Norwalk CT 06855  
203.253.2088

Chief of Operations and Public Works  
125 East Avenue  
Norwalk Ct 06856

Dear Vanessa Valadares,

I hope this letter finds you well. My name is Michelle Petrides and I am writing you today to request naming a street sign.

In accordance to ordinance 95-39, I believe we have met the requirements to make such request. Alexander Restrepo grew up with his family on Lexington Ave ext. although Alex was predeceased by his mother, his father, Horatio still resides in their family home. Alex

passed away suddenly on January 27, 2020. Alex graduated from Brian McMahon High School, whom of which honored him posthumously for being a stand out athlete, but more importantly for his dedicated service in the U.S. Navy. Alex was handpicked to be a part of the first Seal Team Six.

I have enclosed his obituary, which summarizes Alex's 25 years of military service, as well as other documents both public and personal so that you may have more insight as to why this is a special and well deserved honor for him, but most importantly his family.

I am requesting that Lexington Avenue ext. also be named "Master Chief Alexander Restrepo Way" or "MCPON Alexander Restrepo way".

I am aware that there are several steps in procedure. I hope that we can be put on the next public works meeting agenda, with your blessing.

I will bring my petition at that time or at the time of the Public hearing at your request. Thank you for taking the time to read my request. I truly believe if anyone deserves a street sign, it's Alex. I appreciate your attention to this matter and look forward to hearing from you soon.

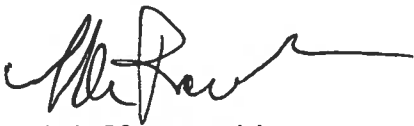

Michelle Petrides  
Michellemaggio4@gmail.com

RECEIVED  
OCT 09 2025  
PUBLIC WORKS

Some things come with age.  
Some others don't.  
Learn the early signs of Alzheimer's.

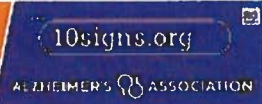

## THE HOUR

🔍 Search by Name

[Restrepo](#) / [Alexander Restrepo](#)

# Alexander Restrepo

🌸 Send Flowers

➦ Share

⊕ Follow

## Alexander Restrepo Obituary

**A**lexander Restrepo Master Chief (SEAL-Ret.) Alexander Restrepo passed away suddenly January 27, 2020. He was born in Costa Rica, grew up in Connecticut, and spent much of his military career in Virginia Beach. Master Chief Restrepo enlisted in the U.S. Navy in 1977, and after a brief tour in the surface navy, he volunteered for Basic Underwater Demolition/SEAL training in Coronado, CA. He served over twenty-five years in Underwater Demolition and SEAL Teams earning a distinguished record of accomplishments. Upon retirement from active duty, as a decorated Master Chief Petty Officer, he pursued a second

career supporting several U.S. Government Agencies and a wide range of private corporations worldwide, including work in Iraq and in the suppression of illegal immigration and drug smuggling near the United States southern border. During his military service, he deployed as a platoon member in Underwater Demolition Team 21 to the Caribbean and the Mediterranean until he was handpicked to join the recently formed SEAL Team SIX, in which he served in increasingly significant leadership positions. Master Chief Restrepo led, and participated in, multiple classified worldwide operations in support of U.S. and foreign governments, militaries, and agencies. He conducted counter insurgency operations in El Salvador and Honduras, combat operations in Granada and Panama; and high-level national security missions involving counter terrorism, counter insurgency and counter narcotics operations worldwide. Most notably, he was recognized as one of the foremost experts in the world in the application of Explosive Breaching, while leading a division responsible for combat engineering, explosives development, and the tactical use of explosives. Alex was a professional, reliable, and loyal teammate, as well as a devoted family man who had the admiration and respect of his fellow warriors. He is leaving indelible memories of shared life experiences in the service of his country and his family. He is survived by his wife Amy, his children Alexandra, Kyle, and Lauren; his father Horacio; his sister Adriana L'Archevesque, her husband Lee and children, Emma, Lily, Lia, and Grace; his brother Marco and his wife Katie and children Nicolas and Elijah; his cousin Victor Fallas, wife Karolyn and sons Tyler and Dean. Alex was predeceased by his mother Iris. A funeral service will be held at Arlington National Cemetery at a later time.

To plant trees in memory, please visit the [Sympathy Store](#).

Published by The Hour on Jan. 31, 2020.

### **Restrepo Pages**

See more records on Ancestry®



## Alexander Restrepo Class of 1977

Alexander Restrepo is being honored posthumously for his dedicated and notable service in the U.S. Navy for over 25 years.

While a student at Brien McMahon, Alexander was a standout athlete, playing outside linebacker on the football team and wrestled 132 pounds on the 1977 State Champion wrestling team. In addition, Alexander earned an individual State champion title in his weight class.

After graduating in 1977, Alexander enlisted in the U.S. Navy in San Diego, CA. After a brief tour in the surface Navy, he volunteered for Basic Underwater Demolition/SEAL training in Coronado, CA. He served over twenty-five years in the Underwater Demolition and SEAL Teams earning a distinguished record of accomplishments.

During his military service he was deployed as a platoon member in Underwater Demolition Team 21 to the Caribbean and the Mediterranean until he was handpicked to join the recently formed SEAL Team SIX, in which he served in increasingly significant leadership positions. Master Chief Restrepo led, and participated in, multiple classified worldwide operations in support of the U.S. and foreign governments, militaries, and agencies. He conducted counter insurgency operations in El Salvador and Honduras, combat operations in Granada and Panama and high-level national security missions involving counter terrorism, counter insurgency, and counter narcotics operations worldwide. He was recognized as one of the foremost experts in the world in the application of Explosive Breaching, while leading a division responsible for combat engineering, explosives development and the tactical use of explosives.

Upon retirement from active duty, as a decorated Master Chief Petty Officer, Alexander pursued a second career supporting several U.S. Government Agencies and a wide range of private corporations worldwide, including work in Iraq and in the suppression of illegal immigration and drug smuggling near the U.S. Southern border.

Alexander died suddenly on January 27, 2020, and was laid to rest in Arlington National Cemetery. He is remembered as a reliable and loyal teammate, classmate, and a great friend to all that knew him.

The Brien McMahon High School Alumni Association is proud to include Alexander Restrepo in the 2023 Hall of Fame.



Alex (R) in Kurdistan.



Ronald Young March 22, 2020

 Share



BMHS 1974 Football Team. Alex is #23 - third row center



Manuel Allende February 3, 2020

 Share



January 31, 2020

**May your rest in Eternal Peace in Frogman Heaven Master CPO  
Restrepo.**

**HooYah!**

**Erasmio "Doc" Rioja**

 Share

◆ AI Overview



An obituary for Alexander Restrepo of Norwalk, CT, who died on January 27, 2020, is available on [Legacy.com](#) and was published in [The Hour](#) newspaper in Virginia Beach, VA. He was a veteran of the U.S. military, serving in counterinsurgency operations and as a member of the recently formed [SEAL Team SIX](#). His military career involved deployments to El Salvador, Honduras, Panama, and the Caribbean.

**Key Details:**

- **Name:** Alexander Restrepo
- **Date of Death:** January 27, 2020
- **Location:** Norwalk, CT
- **Service:** U.S. military, including counterinsurgency and SEAL Team SIX operations

For further details, you can visit

[Legacy.com](#).

**Alexander Restrepo  
Obituary (2020) - Virgini...**

Jan 31, 2020 — How to support Alexander's loved ones. Honor a...

Legacy.com



Ne  
al  
Oc  
th  
TH

Q obituary for alexander restrepo norwal ct — Private

## Chapter 95. Streets and Sidewalks

### Article II. Honorary and Historic Naming of Streets

[Adopted 10-28-2014]

#### § 95-37. Purpose.

The purpose of this article is to establish guidelines and formalize procedures when considering the honorary or historic naming or renaming of a City-owned or controlled street or roadway, administered under the responsibility charged to the Public Works Committee of the Common Council.

#### § 95-38. Policy and considerations.

[Amended 4-14-2020]

If a City street or roadway is to be named in honor of an individual, it is generally required that such individual has made a significant contribution to the community through public service and deeds, and is respected for his or her accomplishments and good conduct. Consideration shall be given to individuals who have made recent accomplishments and contributions as well as individuals with historic ties to the City. An individual shall be deceased at least one year prior to the naming unless the Common Council determines by a two-thirds-majority plus one (11 votes) that a living individual or a person who has been deceased less than one year deserves the honor. Groups should not be in a position to influence the process by funding of past or future operations of the street or roadway, and it is ultimately important for the City to avoid any perception of improper manipulation, special favor, vested interest, or endorsement of businesses, products or services.

#### § 95-39. Procedure.

[Amended 4-14-2020]

Naming of City streets or roadways shall proceed as follows:

- A. The proposed naming of a City street or roadway shall be placed on a Public Works regular meeting agenda for discussion and review. In the event that the street or roadway to be named is located within a City park, the proposed naming shall be placed on the Recreation, Parks and Cultural Affairs agenda for discussion and review.
- B. A public hearing is required prior to forwarding the naming request to the full Common Council for approval. The hearing shall be held at a regular meeting of the Public Works Committee, and the scheduling of said hearing shall have been approved at a previous regular meeting by a majority vote of the Committee.
- C. A two-thirds-majority (10 votes) of the Common Council is required for the approval of all honorary or historic street names, except in the case where a living individual or a person who has been deceased less than one year is the honoree, in which case a two-thirds-majority plus one (11 votes) is required.

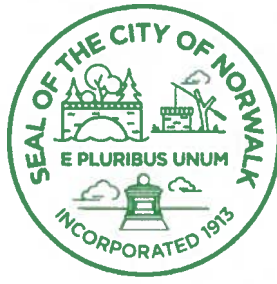

## Contract Staff Summary

<b>Department/Staff Contact</b>	Public Works Engineering/Paul Sotnik x47891
<b>City Council Committee</b>	Public Works Committee
<b>Date Approved by Committee</b>	
<b>Purpose/Scope</b>	Honorary Naming of a portion of West Avenue.
<b>Vendor</b> (Indicate if new or existing vendor)	N/A
<b>Term of Contract</b>	N/A
<b>Method of Procurement</b> (Indicate if sole source)	
<b>Cost of Contract</b>	
<b>Funding Source/Account Number</b>	
<b>Additional Information/Other Details</b>	Public Hearing – 2/3/2026



City of Norwalk  
Paul Sotnik, P.E.  
Senior Civil Engineer / Department of Engineering  
125 East Avenue  
Norwalk, CT 06856-5125  
Office Telephone: (203) 854-7891  
[www.norwalkct.gov](http://www.norwalkct.gov)  
E-Mail: [psotnik@norwalkct.gov](mailto:psotnik@norwalkct.gov)

## MEMORANDUM

**TO:** Vanessa Valadares, P.E. - Chief of Operations and Public Works

**FROM:** Paul L. Sotnik, P.E. - Senior Civil Engineer 

**CC:** James Meehan, P.E. - Principal Engineer

**REF:** Stanley Seligson Way  
Public Hearing and Action Item For the Honorary Naming of a portion of West Avenue

**DATE:** January 16, 2026

---

Mr. Michael Serrao and Ms. Jessica Potter delivered a request letter and package of supporting backup information concerning the above referenced topic to Mayor Rilling on October 29, 2025, requesting that the portion of West Avenue from Wall Street to Connecticut Avenue/Mathews Park be named Stanley Seligson Way in honor of his Redevelopment efforts, specifically in that area of West Avenue and his contributions to the City of Norwalk.

The proposed Honorary Street Name signs would be installed at the following locations. I have attached a map for reference.

- On Werst Avenue at the intersection of Wall Street.
- On West Avenue at the intersection Connecticut Avenue/Mathews Park.

On December 2, 2025 at their regularly scheduled meeting, the Public Works Committee of the City Council acknowledged the receipt of the request for the Honorary naming of the portion of West Avenue from Wall Street to Connecticut Avenue/Mathews Park to Stanley Seligson Way and called for the scheduling of a Public Hearing on Tuesday, February 3, 2026 at 7:15 P.M. concerning the topic in order to hear all parties interested in commenting on the proposed Honorary Street naming and to take such action on said naming that the Committee may deem advisable.

Therefore, I would like to request that the following Items be included on the agenda for the February 3, 2026 meeting of the Public Works Committee of the City Council for approval.

### Public Hearing

Conduct a Public Hearing to hear all parties interested in commenting on the proposed Honorary Street naming of the portion of West Avenue from Wall Street to Connecticut Avenue/Mathews Park to Stanley Seligson Way at 7:15 P.M.



City of Norwalk  
**Paul Sotnik, P.E.**  
*Senior Civil Engineer / Department of Engineering*  
125 East Avenue  
Norwalk, CT 06856-5125  
Office Telephone: (203) 854-7891  
[www.norwalkct.gov](http://www.norwalkct.gov)  
E-Mail: [psotnik@norwalkct.gov](mailto:psotnik@norwalkct.gov)

### New Business

Approve the Honorary naming of the portion of West Avenue from Wall Street to Connecticut Avenue/Mathews Park to Stanley Seligson Way.

I have attached a copy of Chapter 95 Streets and Sidewalks Article II Honorary and Historic Naming of Streets for reference.

If you have any questions, please do not hesitate to contact me.



CITY OF NORWALK  
**Harry W. Rilling**  
**Mayor**  
*hrilling@norwalkct.gov*  
p: 203-854-7294  
Norwalk City Hall  
125 East Avenue, PO Box 5125

Seligson Properties  
Norwalk, CT 06856  
605 West Avenue

December 1, 2025

Re: Request for Honorary Street Naming in Recognition of Stanley M. Seligson

Good afternoon, Seligson Properties,

It's my honor to support your proposal to recognize the legacy of Stanley M. Seligson through the City's honorary street naming program, by naming a portion of West Avenue "Stanley M. Seligson."

Stanley Seligson was born in Norwalk in 1933 and attended Norwalk schools. After becoming a successful real estate investor, he decided to give back to his community. In 1979, he formed Seligson Properties and, through his development work, helped transform the West Avenue section of Norwalk.

He was civic-minded and worked closely with the City of Norwalk on several public-private partnerships, including the City's "West Avenue Redevelopment Plan." This effort helped enhance the vibrancy of the West Avenue corridor.

As an active member of the community, he served as an advisor and board member to many Norwalk institutions, including the Greater Norwalk Chamber of Commerce, the Maritime Aquarium and the Lockwood-Mathews Mansion Museum, among others.

Given Mr. Seligson's deep connection to Norwalk and decades of contributions to this stretch of West Avenue, naming this portion of the street after him is an appropriate and meaningful way to honor his legacy.

Please don't hesitate to contact me if I can be of any assistance during this process.

A handwritten signature in black ink that reads "Harry W. Rilling". The signature is fluid and cursive.

Mayor Harry W. Rilling

605 West Avenue  
Norwalk, Connecticut 06850  
Phone: (203) 857-5600  
[www.seligsonproperties.com](http://www.seligsonproperties.com)



---

May 7, 2025

The Honorable Harry W. Rilling  
Mayor, City of Norwalk  
Norwalk City Hall  
125 East Avenue, PO Box 5125  
Norwalk, CT 06851  
*Via email:* [hrilling@norwalkct.org](mailto:hrilling@norwalkct.org)

**Re: Request for Honorary Street Naming in Recognition of Stanley M. Seligson;  
A portion of West Avenue, from Wall Street to Connecticut Avenue (Mathews Park)**

Dear Mayor Rilling,

Thank you again for taking the time to meet with me recently and for your support of our proposal to recognize the legacy of Stanley M. Seligson through the City's honorary street naming program.

On behalf of Seligson Properties, I respectfully request that a portion of West Avenue, specifically from the intersections of Wall Street (to the North) to Connecticut Avenue/Mathews Park (to the South), be designated in his honor. This stretch of West Avenue was a central focus of Mr. Seligson's professional efforts since the 1970's and includes an area subject to the City's "West Avenue Redevelopment Plan," a long-term initiative in which Mr. Seligson and our firm were proud to be active participants for more than a decade through a public-private partnership with the City of Norwalk.

Stanley M. Seligson was a visionary real estate investor, developer, and civic-minded business leader who played an instrumental role in shaping the West Avenue corridor and contributing to Norwalk's economic revitalization. Through investments in commercial properties, collaboration with city planners and agencies, and a commitment to the long-term success of the area, Mr. Seligson left an enduring mark on the City's landscape and business environment.

For your reference, we have enclosed a GIS parcel map highlighting the properties along West Avenue that Mr. Seligson and our firm currently own or have been historically associated with. These parcels reflect a sustained commitment to the corridor's improvement and continued vitality.

We believe that an honorary street naming would be a meaningful and appropriate way to recognize Mr. Seligson's decades of contributions to Norwalk and his deep connection to this important stretch of West Avenue. We welcome the opportunity to work with your office and the appropriate City bodies to move this forward and are happy to provide supporting documentation or attend any meetings necessary as part of the process. Thank you again for your consideration and support.

Sincerely,

A handwritten signature in black ink that reads 'Michael G. Serrao'. The signature is written in a cursive, flowing style.

Michael G. Serrao  
President & CEO

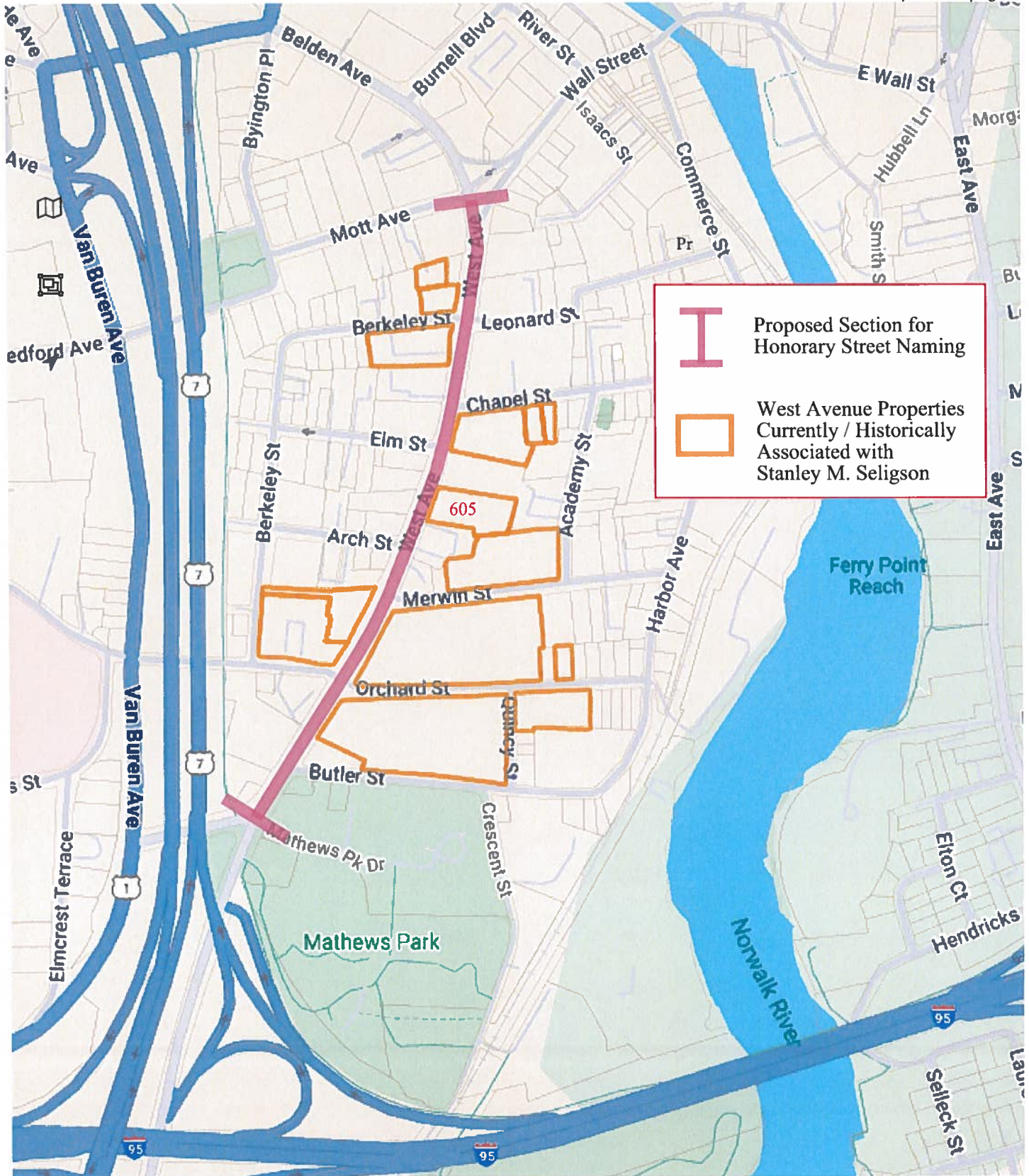



2019 AERIAL PHOTO DATA

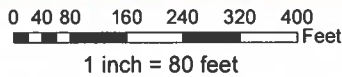

# STANLEY SELIGSON WAY

## Chapter 95. Streets and Sidewalks

### Article II. Honorary and Historic Naming of Streets

[Adopted 10-28-2014]

#### § 95-37. Purpose.

The purpose of this article is to establish guidelines and formalize procedures when considering the honorary or historic naming or renaming of a City-owned or controlled street or roadway, administered under the responsibility charged to the Public Works Committee of the Common Council.

#### § 95-38. Policy and considerations.

[Amended 4-14-2020]

If a City street or roadway is to be named in honor of an individual, it is generally required that such individual has made a significant contribution to the community through public service and deeds, and is respected for his or her accomplishments and good conduct. Consideration shall be given to individuals who have made recent accomplishments and contributions as well as individuals with historic ties to the City. An individual shall be deceased at least one year prior to the naming unless the Common Council determines by a two-thirds-majority plus one (11 votes) that a living individual or a person who has been deceased less than one year deserves the honor. Groups should not be in a position to influence the process by funding of past or future operations of the street or roadway, and it is ultimately important for the City to avoid any perception of improper manipulation, special favor, vested interest, or endorsement of businesses, products or services.

#### § 95-39. Procedure.

[Amended 4-14-2020]

Naming of City streets or roadways shall proceed as follows:

- A. The proposed naming of a City street or roadway shall be placed on a Public Works regular meeting agenda for discussion and review. In the event that the street or roadway to be named is located within a City park, the proposed naming shall be placed on the Recreation, Parks and Cultural Affairs agenda for discussion and review.
- B. A public hearing is required prior to forwarding the naming request to the full Common Council for approval. The hearing shall be held at a regular meeting of the Public Works Committee, and the scheduling of said hearing shall have been approved at a previous regular meeting by a majority vote of the Committee.
- C. A two-thirds-majority (10 votes) of the Common Council is required for the approval of all honorary or historic street names, except in the case where a living individual or a person who has been deceased less than one year is the honoree, in which case a two-thirds-majority plus one (11 votes) is required.

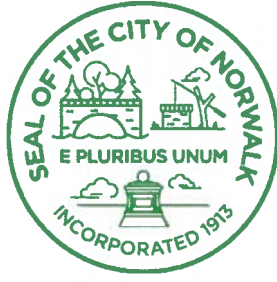

## Contract Staff Summary

<b>Department/Staff Contact</b>	Public Works Engineering/Paul Sotnik x47891
<b>City Council Committee</b>	Public Works Committee
<b>Date Approved by Committee</b>	
<b>Purpose/Scope</b>	Honorary Naming of Knight Street.
<b>Vendor</b> (Indicate if new or existing vendor)	N/A
<b>Term of Contract</b>	N/A
<b>Method of Procurement</b> (Indicate if sole source)	
<b>Cost of Contract</b>	
<b>Funding Source/Account Number</b>	
<b>Additional Information/Other Details</b>	Acknowledge Receipt of request and schedule Public Hearing – 3/3/2026



City of Norwalk  
Paul Sotnik, P.E.  
Senior Civil Engineer / Department of Engineering  
125 East Avenue  
Norwalk, CT 06856-5125  
Office Telephone: (203) 854-7891  
[www.norwalkct.gov](http://www.norwalkct.gov)  
E-Mail: [psotnik@norwalkct.gov](mailto:psotnik@norwalkct.gov)

## MEMORANDUM

**TO:** Vanessa Valadares, P.E. - Chief of Operations and Public Works

**FROM:** Paul L. Sotnik, P.E. - Senior Civil Engineer 

**CC:** James Meehan, P.E. - Principal Engineer

**REF:** Cutie Mae Jordan Way  
Acknowledge Receipt of Request and Schedule Public a Hearing For the Honorary Naming of Knight Street

**DATE:** January 16, 2026

---

Mr. Kyle Jordan contacted us concerning the above referenced topic. Mr. Jordan sent a request letter and package of supporting backup information, requesting that Knight Street be named Cutie Mae Jordan Way in honor of Ms. Jordan's service to the community.

The proposed Honorary Street Name signs would be installed at the following locations. I have attached a map for reference.

- On Knight Street at the intersection of Wall Street.
- On Knight Street at the intersection of North Avenue (U.S. Route 1).

Therefore, I would like to request that the following Items be included on the agenda for the February 3, 2026 meeting of the Public Works Committee of the City Council for approval.

- 1.) Acknowledge the receipt of the request for the Honorary naming of Knight Street to Cutie Mae Jordan Way.
- 2.) Schedule a Public Hearing for the Honorary naming of Knight Street to Cutie Mae Jordan Way. The Public Hearing shall be conducted in order to hear all parties interested in commenting on the proposed Honorary Street naming and to take such action on said naming that the Committee may deem advisable. The Public Hearing is scheduled for Tuesday, March 3, 2026 at 7:00 P.M. by way of Videoconference/Teleconference.

If you have any questions, please do not hesitate to contact me.



CUTIE MAE JORDAN WAY

0 30 60 120 180 240 300 Feet  
1 inch = 60 feet

2019 AERIAL PHOTO DATA



## Bio

Cutie Mae Jordan was born and raised in Cape Charles, Virginia, the daughter of the late Walter W. and Josephine Wynder Sewell. She graduated from North Hampton County High School and attended Norfolk State University and Norwalk Community College.

At the age of twelve, she joined the St. Stephens A.M.E. Church in Cape Charles where she directed her first choir and became their only organist for seven years. She was a member of the Music Guild at Hampton Institute under the direction of Professor Charles Flat. Mrs. Jordan is a well-known gospel singer throughout the metropolitan area, she was the founder of the Roodner Court Bible School (known for its annual Easter Pageants), the founder of the Women's Guild at Mount Zion Baptist, Norwalk, the founder and director of the Shilohettes of Shiloh Baptist Church, Norwalk. She was the director of the Calvary Gospel Choir, Calvary Senior Choir and the Calvarettes at Calvary Baptist Church, director of the J.W.T. Gospel Choir and Male Chorus at Bethel A.M.E. Church Norwalk, director of the First Congregational Church Gospel Choir, and the founder and director of the Jordan Concert Singers of Norwalk. **In June 2008, she sang the National Anthem at the Pentagon in Arlington, Virginia.** She was interviewed on Channel 12 News Connecticut by Gwen Edwards on 'Our Lives' where she performed her signature song 'Too Close'. She performed at Norwalk Public Schools for Black History Month and Martin L. King programs. Performed at Senior Nursing Homes at Westport Health Center, Jewish Nursing Home and Ludlow Commons Senior Citizens. Composed music, directed and performed for May Fellowship along with the late Emma Gilmore (President of CWU/Norwalk Public School Teacher) for the Church Women United. Performed at dedication ceremonies for the Norwalk Heritage Wall for African Americans and the Historic Norwalk Matthew Mansion. In addition to her ministering she also served on the Board of Directors at N.E.O.N as Chairman of Affirmative Action. She has received numerous awards for her dedicated and tireless work in the church and communities including an Official Citation from the State of Connecticut Office of the Attorney General Richard Blumenthal (Current: Connecticut U.S. Senator), an Official Statement from the State of Connecticut Governor M. Jodi Rell and Proclamations from the City of Norwalk Mayor Richard A. Moccia and Mayor Harry W. Rilling. Mrs. Jordan continues to minister through her music and as she respectfully puts it, with her G.F.G 'Gift From God'.

Mrs. Jordan was married to the late Calvin E. Jordan Sr. for 53 years and to their union they had six children. The late Calvin E. Jordan Jr, the late Kern A. Jordan, Reginald Carnell Jordan, Steve Christopher Jordan, Sean Jordan Owens and Kesha Jordan Allen. She has Twenty-two grandchildren and fifteen great-grandchildren.

## **Highlights from Bio:**

**1940:** At age 5 she learned to play the piano by ear from listening to the radio and music while attending church. Her father who sung on the Do Re Mi Quartet taught her how to utilize the do re mi scale to help her learn melodies while singing and playing the piano.

**1947:** At the age of 12 she directed and became the organist for the Gospel Choir at St. Stephens A.M.E. church in Cape Charles, Virginia where she later became a member.

**1951:** At the age of 16 on Thursday, March 9th she performed at the Hampton Institute, 'Chapel of Soldiers Home' with the Music Guild of Cape Charles, Virginia under the direction of Professor Charles Flat.

## **1955-Present:**

- **On April 7, 1968, three days after the assassination of Dr. Martin Luther King 3000 People marched to the Green in Norwalk CT. mourning the loss of MLK, she was called to sing and lead the people in song, 'The Battle Hymn of the Republic.' She also sang one of MLK's favorite hymns 'Precious Lord', and We Shall Overcome.**
- 1970's – Norwalk CT., she was the lead vocalist at the Martin L. King Day annual memorial service singing 'Go Tell It On The Mountain' as the combine choir marched in.
- In the 1970's she was the Founder of the Roodner Court Bible School known for their annual Easter Plays, 'The Old Rugged Cross.'
- Founder of the Women's Guild at Mount Zion Baptist Church, Norwalk, CT.
- Founder and Director/Pianist of the Shilohettes of Shiloh Baptist Church, Norwalk CT.
- Director/Pianist of the Calvary Gospel Choir, Senior Choir, and the Calvarettes at Calvary Baptist Church, Norwalk, CT.
- Director/Pianist of the J.W.T. Gospel Choir and Male Chorus at Bethel A.M.E. Church, Norwalk, CT.
- Founder and Director/Pianist of the Jordan Concert Singers of Norwalk, CT.
- Director of the FCC Gospel Choir at First Congregational Church, Norwalk, CT.
- She was interviewed on Channel 12 News Connecticut by Gwen Edwards on 'Our Lives Show' where she performed her signature song 'Too Close'.

- She performed at Norwalk Public Schools for Black History Month and Martin Luther King programs.
- She performed at Senior Nursing Homes at the Westport Health Center, Jewish Nursing Home, and Ludlow Commons for Senior Citizens.
- She composed music, directed, and performed for May Fellowship along with the late Emma Gilmore (President of the CWU/Norwalk Public School Teacher), and performed for the Church Women United.
- Performed at dedication ceremonies for the Norwalk Heritage Wall for African Americans and the Historic Norwalk Matthew Mansion.

**Other Historical Events/Awards:**

- In addition to her ministry in music she served on Board of Directors at N.E.O.N. (Norwalk Economic Opportunity Now) as Chairman of Affirmative Action.

**June 2008: She sang the National Anthem at the Pentagon in Arlington, VA.**

- She received numerous awards for her dedicated and tireless work in the church and communities including:
  1. Official Citation from the State of Connecticut Office of the Attorney General Richard Blumenthal (Currently, Connecticut U.S. Senator).
  2. Official Statement from the State of Connecticut Governor M. Jodi Rell.
  3. Proclamation from the City of Norwalk by Mayor Richard A. Moccia and the current Mayor Harry W. Rilling.
  4. Humanitarian Award from the City of Norwalk by Mayor Harry W. Rilling.
  5. State of Connecticut General Assembly Citation presented to her by CT. Senate Majority Leader Bob Duff.
  6. Honored at an award banquet dinner ceremony at the Norwalk Inn and received the Gospel Legend Award from Shiloh Baptist Church, Norwalk, Connecticut.

## Chapter 95. Streets and Sidewalks

### Article II. Honorary and Historic Naming of Streets

[Adopted 10-28-2014]

#### § 95-37. Purpose.

The purpose of this article is to establish guidelines and formalize procedures when considering the honorary or historic naming or renaming of a City-owned or controlled street or roadway, administered under the responsibility charged to the Public Works Committee of the Common Council.

#### § 95-38. Policy and considerations.

[Amended 4-14-2020]

If a City street or roadway is to be named in honor of an individual, it is generally required that such individual has made a significant contribution to the community through public service and deeds, and is respected for his or her accomplishments and good conduct. Consideration shall be given to individuals who have made recent accomplishments and contributions as well as individuals with historic ties to the City. An individual shall be deceased at least one year prior to the naming unless the Common Council determines by a two-thirds-majority plus one (11 votes) that a living individual or a person who has been deceased less than one year deserves the honor. Groups should not be in a position to influence the process by funding of past or future operations of the street or roadway, and it is ultimately important for the City to avoid any perception of improper manipulation, special favor, vested interest, or endorsement of businesses, products or services.

#### § 95-39. Procedure.

[Amended 4-14-2020]

Naming of City streets or roadways shall proceed as follows:

- A. The proposed naming of a City street or roadway shall be placed on a Public Works regular meeting agenda for discussion and review. In the event that the street or roadway to be named is located within a City park, the proposed naming shall be placed on the Recreation, Parks and Cultural Affairs agenda for discussion and review.
- B. A public hearing is required prior to forwarding the naming request to the full Common Council for approval. The hearing shall be held at a regular meeting of the Public Works Committee, and the scheduling of said hearing shall have been approved at a previous regular meeting by a majority vote of the Committee.
- C. A two-thirds-majority (10 votes) of the Common Council is required for the approval of all honorary or historic street names, except in the case where a living individual or a person who has been deceased less than one year is the honoree, in which case a two-thirds-majority plus one (11 votes) is required.

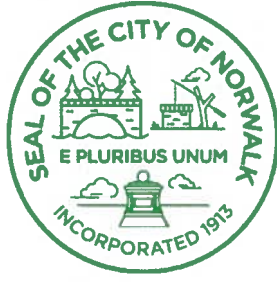

## Contract Staff Summary

<b>Department/Staff Contact</b>	Public Works Engineering/Paul Sotnik x47891
<b>City Council Committee</b>	Public Works Committee
<b>Date Approved by Committee</b>	
<b>Purpose/Scope</b>	Honorary Naming of Knight Street.
<b>Vendor</b> (Indicate if new or existing vendor)	N/A
<b>Term of Contract</b>	N/A
<b>Method of Procurement</b> (Indicate if sole source)	
<b>Cost of Contract</b>	
<b>Funding Source/Account Number</b>	
<b>Additional Information/Other Details</b>	Acknowledge Receipt of request and schedule Public Hearing – 3/3/2026



City of Norwalk  
Paul Sotnik, P.E.  
Senior Civil Engineer / Department of Engineering  
125 East Avenue  
Norwalk, CT 06856-5125  
Office Telephone: (203) 854-7891  
[www.norwalkct.gov](http://www.norwalkct.gov)  
E-Mail: [psotnik@norwalkct.gov](mailto:psotnik@norwalkct.gov)

## MEMORANDUM

**TO:** Vanessa Valadares, P.E. - Chief of Operations and Public Works

**FROM:** Paul L. Sotnik, P.E. - Senior Civil Engineer 

**CC:** James Meehan, P.E. - Principal Engineer

**REF:** Cutie Mae Jordan Way  
Acknowledge Receipt of Request and Schedule Public a Hearing For the Honorary Naming of Knight Street

**DATE:** January 16, 2026

---

Mr. Kyle Jordan contacted us concerning the above referenced topic. Mr. Jordan sent a request letter and package of supporting backup information, requesting that Knight Street be named Cutie Mae Jordan Way in honor of Ms. Jordan's service to the community.

The proposed Honorary Street Name signs would be installed at the following locations. I have attached a map for reference.

- On Knight Street at the intersection of Wall Street.
- On Knight Street at the intersection of North Avenue (U.S. Route 1).

Therefore, I would like to request that the following Items be included on the agenda for the February 3, 2026 meeting of the Public Works Committee of the City Council for approval.

- 1.) Acknowledge the receipt of the request for the Honorary naming of Knight Street to Cutie Mae Jordan Way.
- 2.) Schedule a Public Hearing for the Honorary naming of Knight Street to Cutie Mae Jordan Way. The Public Hearing shall be conducted in order to hear all parties interested in commenting on the proposed Honorary Street naming and to take such action on said naming that the Committee may deem advisable. The Public Hearing is scheduled for Tuesday, March 3, 2026 at 7:00 P.M. by way of Videoconference/Teleconference.

If you have any questions, please do not hesitate to contact me.



CUTIE MAE JORDAN WAY

0 30 60 120 180 240 300 Feet  
1 inch = 60 feet

2019 AERIAL PHOTO DATA



## Bio

Cutie Mae Jordan was born and raised in Cape Charles, Virginia, the daughter of the late Walter W. and Josephine Wynder Sewell. She graduated from North Hampton County High School and attended Norfolk State University and Norwalk Community College.

At the age of twelve, she joined the St. Stephens A.M.E. Church in Cape Charles where she directed her first choir and became their only organist for seven years. She was a member of the Music Guild at Hampton Institute under the direction of Professor Charles Flat. Mrs. Jordan is a well-known gospel singer throughout the metropolitan area, she was the founder of the Roodner Court Bible School (known for its annual Easter Pageants), the founder of the Women's Guild at Mount Zion Baptist, Norwalk, the founder and director of the Shilohettes of Shiloh Baptist Church, Norwalk. She was the director of the Calvary Gospel Choir, Calvary Senior Choir and the Calvarettes at Calvary Baptist Church, director of the J.W.T. Gospel Choir and Male Chorus at Bethel A.M.E. Church Norwalk, director of the First Congregational Church Gospel Choir, and the founder and director of the Jordan Concert Singers of Norwalk. **In June 2008, she sang the National Anthem at the Pentagon in Arlington, Virginia.** She was interviewed on Channel 12 News Connecticut by Gwen Edwards on 'Our Lives' where she performed her signature song 'Too Close'. She performed at Norwalk Public Schools for Black History Month and Martin L. King programs. Performed at Senior Nursing Homes at Westport Health Center, Jewish Nursing Home and Ludlow Commons Senior Citizens. Composed music, directed and performed for May Fellowship along with the late Emma Gilmore (President of CWU/Norwalk Public School Teacher) for the Church Women United. Performed at dedication ceremonies for the Norwalk Heritage Wall for African Americans and the Historic Norwalk Matthew Mansion. In addition to her ministering she also served on the Board of Directors at N.E.O.N as Chairman of Affirmative Action. She has received numerous awards for her dedicated and tireless work in the church and communities including an Official Citation from the State of Connecticut Office of the Attorney General Richard Blumenthal (Current: Connecticut U.S. Senator), an Official Statement from the State of Connecticut Governor M. Jodi Rell and Proclamations from the City of Norwalk Mayor Richard A. Moccia and Mayor Harry W. Rilling. Mrs. Jordan continues to minister through her music and as she respectfully puts it, with her G.F.G 'Gift From God'.

Mrs. Jordan was married to the late Calvin E. Jordan Sr. for 53 years and to their union they had six children. The late Calvin E. Jordan Jr, the late Kern A. Jordan, Reginald Carnell Jordan, Steve Christopher Jordan, Sean Jordan Owens and Kesha Jordan Allen. She has Twenty-two grandchildren and fifteen great-grandchildren.

## **Highlights from Bio:**

- 1940:** At age 5 she learned to play the piano by ear from listening to the radio and music while attending church. Her father who sung on the Do Re Mi Quartet taught her how to utilize the do re mi scale to help her learn melodies while singing and playing the piano.
- 1947:** At the age of 12 she directed and became the organist for the Gospel Choir at St. Stephens A.M.E. church in Cape Charles, Virginia where she later became a member.
- 1951:** At the age of 16 on Thursday, March 9th she performed at the Hampton Institute, 'Chapel of Soldiers Home' with the Music Guild of Cape Charles, Virginia under the direction of Professor Charles Flat.

## **1955-Present:**

- **On April 7, 1968, three days after the assassination of Dr. Martin Luther King 3000 People marched to the Green in Norwalk CT. mourning the loss of MLK, she was called to sing and lead the people in song, 'The Battle Hymn of the Republic.' She also sang one of MLK's favorite hymns 'Precious Lord', and We Shall Overcome.**
- 1970's – Norwalk CT., she was the lead vocalist at the Martin L. King Day annual memorial service singing 'Go Tell It On The Mountain' as the combine choir marched in.
- In the 1970's she was the Founder of the Roodner Court Bible School known for their annual Easter Plays, 'The Old Rugged Cross.'
- Founder of the Women's Guild at Mount Zion Baptist Church, Norwalk, CT.
- Founder and Director/Pianist of the Shilohettes of Shiloh Baptist Church, Norwalk CT.
- Director/Pianist of the Calvary Gospel Choir, Senior Choir, and the Calvarettes at Calvary Baptist Church, Norwalk, CT.
- Director/Pianist of the J.W.T. Gospel Choir and Male Chorus at Bethel A.M.E. Church, Norwalk, CT.
- Founder and Director/Pianist of the Jordan Concert Singers of Norwalk, CT.
- Director of the FCC Gospel Choir at First Congregational Church, Norwalk, CT.
- She was interviewed on Channel 12 News Connecticut by Gwen Edwards on 'Our Lives Show' where she performed her signature song 'Too Close'.

- She performed at Norwalk Public Schools for Black History Month and Martin Luther King programs.
- She performed at Senior Nursing Homes at the Westport Health Center, Jewish Nursing Home, and Ludlow Commons for Senior Citizens.
- She composed music, directed, and performed for May Fellowship along with the late Emma Gilmore (President of the CWU/Norwalk Public School Teacher), and performed for the Church Women United.
- Performed at dedication ceremonies for the Norwalk Heritage Wall for African Americans and the Historic Norwalk Matthew Mansion.

**Other Historical Events/Awards:**

- In addition to her ministry in music she served on Board of Directors at N.E.O.N. (Norwalk Economic Opportunity Now) as Chairman of Affirmative Action.

**June 2008: She sang the National Anthem at the Pentagon in Arlington, VA.**

- She received numerous awards for her dedicated and tireless work in the church and communities including:
  1. Official Citation from the State of Connecticut Office of the Attorney General Richard Blumenthal (Currently, Connecticut U.S. Senator).
  2. Official Statement from the State of Connecticut Governor M. Jodi Rell.
  3. Proclamation from the City of Norwalk by Mayor Richard A. Moccia and the current Mayor Harry W. Rilling.
  4. Humanitarian Award from the City of Norwalk by Mayor Harry W. Rilling.
  5. State of Connecticut General Assembly Citation presented to her by CT. Senate Majority Leader Bob Duff.
  6. Honored at an award banquet dinner ceremony at the Norwalk Inn and received the Gospel Legend Award from Shiloh Baptist Church, Norwalk, Connecticut.

## Chapter 95. Streets and Sidewalks

### Article II. Honorary and Historic Naming of Streets

[Adopted 10-28-2014]

#### § 95-37. Purpose.

The purpose of this article is to establish guidelines and formalize procedures when considering the honorary or historic naming or renaming of a City-owned or controlled street or roadway, administered under the responsibility charged to the Public Works Committee of the Common Council.

#### § 95-38. Policy and considerations.

[Amended 4-14-2020]

If a City street or roadway is to be named in honor of an individual, it is generally required that such individual has made a significant contribution to the community through public service and deeds, and is respected for his or her accomplishments and good conduct. Consideration shall be given to individuals who have made recent accomplishments and contributions as well as individuals with historic ties to the City. An individual shall be deceased at least one year prior to the naming unless the Common Council determines by a two-thirds-majority plus one (11 votes) that a living individual or a person who has been deceased less than one year deserves the honor. Groups should not be in a position to influence the process by funding of past or future operations of the street or roadway, and it is ultimately important for the City to avoid any perception of improper manipulation, special favor, vested interest, or endorsement of businesses, products or services.

#### § 95-39. Procedure.

[Amended 4-14-2020]

Naming of City streets or roadways shall proceed as follows:

- A. The proposed naming of a City street or roadway shall be placed on a Public Works regular meeting agenda for discussion and review. In the event that the street or roadway to be named is located within a City park, the proposed naming shall be placed on the Recreation, Parks and Cultural Affairs agenda for discussion and review.
- B. A public hearing is required prior to forwarding the naming request to the full Common Council for approval. The hearing shall be held at a regular meeting of the Public Works Committee, and the scheduling of said hearing shall have been approved at a previous regular meeting by a majority vote of the Committee.
- C. A two-thirds-majority (10 votes) of the Common Council is required for the approval of all honorary or historic street names, except in the case where a living individual or a person who has been deceased less than one year is the honoree, in which case a two-thirds-majority plus one (11 votes) is required.



## Contract Staff Summary

<b>Department/Staff Contact</b>	WPCA / Mario Pizighelli x 44162
<b>City Council Committee</b>	Public Works Committee
<b>Date Approved by Committee</b>	
<b>Purpose/Scope</b>	DRG2023-3 On Call Drainage Improvements at Various Locations
<b>Vendor</b> (Indicate if new or existing vendor)	M. Rondano, Inc.
<b>Term of Contract</b>	4 <sup>th</sup> Amendment / 1 year
<b>Method of Procurement</b> (Indicate if sole source)	
<b>Cost of Contract</b>	\$1,124,616.15 \$112,461.62 contingency
<b>Funding Source/Account Number</b>	09 20 4062 5777 C0361 09 24 4062 5777 C0361 09 24 4021 5777 C0302 09 25 4021 5777 C0302 09 26 4021 5777 C0302 09 24 4021 5777 C0021 09 25 4021 5777 C0021 09 26 4021 5777 C0021 09 21 4021 5777 C0440 09 22 4021 5777 C0440 09 24 4021 5777 C0440

09 25 4021 5777 C0440  
09 26 4021 5777 C0440  
09 20 4027 5777 C0643  
09 21 4021 5777 C0643  
09 22 4021 5777 C0643  
09 25 4021 5777 C0643  
09 26 4021 5777 C0643  
09 25 4021 5777 C0715  
09 26 4021 5777 C0715

**Additional Information/Other Details**



CITY OF NORWALK  
**Mario Pizighelli, P.E.**  
*Stormwater Systems Manager*  
*Department of Engineering*  
125 East Avenue  
Norwalk, CT 06856  
Office: 203 -854- 4162  
mpizighelli@norwalkct.gov

**MEMORANDUM**

**TO:** Vanessa Valadares, P.E. – Chief of Operations and Public Works

**CC:** James Meehan, P.E. – Principal Engineer

**FROM:** Mario Pizighelli, P.E. – Stormwater Systems Manager

**RE:** DRG 2023-3 On Call Drainage Improvements at Various Locations

**DATE:** January 20, 2026

---

On December 12<sup>th</sup>, 2023 Common Council approved the action item to authorize the Mayor, Harry W. Rilling to execute an Agreement between the City of Norwalk and M. Rondano Inc. for Purchasing Project 4322, DRG 2023-3 On Call Drainage Improvements at Various Locations for a sum not to exceed \$1,020,060.00. The project consists of improving the City's storm drainage systems that are within the City's paving program with flexibility to perform any potential emergency drainage improvements on an on-call basis. Within the contract Bid Documents, there is a special note stating The City has an option to extend this Agreement for two (2) additional terms of one (1) year each. In the event that The City chooses to extend the contract for additional years, the contract unit bid items will be increased by 5% each additional year.

I recommend extending the contract for its final one (1) year term into February 2027. The Contractor, M. Rondano Inc., has fulfilled their obligations in timely and effective manner. Their work and expertise has proven to be beneficial in improving Norwalk's current drainage infrastructure prior to road paving and concrete sidewalk installation, resulting in more roads being ready for road reconstruction without delay. I believe that extending the contract shall provide a more efficient road reconstruction program for future paving projects and would greatly benefit The City of Norwalk.

I would like to request that the following items be included on the agenda for the February 2026 Public Works Committee meeting

1. Authorize the Mayor, Barbara C. Smyth, to execute the 4<sup>th</sup> Amendment to the December 12, 2023 agreement between the City of Norwalk and M. Rondano Inc. for Purchasing



CITY OF NORWALK  
**Mario Pizighelli, P.E.**  
**Stormwater Systems Manager**  
**Department of Engineering**  
125 East Avenue  
Norwalk, CT 06856  
Office: 203 -854- 4162  
mpizighelli@norwalkct.gov

Project 4322, DRG 2023-3 On Call Drainage at Various Locations for a sum not to exceed \$1,124,616.15

2. Authorize the Chief of Operations and Public Works to execute orders on the contract with M. Rondano, Inc. for project DRG2023-3 On-Call Drainage Improvements at Various Locations for a sum not to exceed \$112,461.62

Account No.

09 20 4062 5777 C0361  
09 24 4062 5777 C0361  
09 24 4021 5777 C0302  
09 25 4021 5777 C0302  
09 26 4021 5777 C0302  
09 24 4021 5777 C0021  
09 25 4021 5777 C0021  
09 26 4021 5777 C0021  
09 21 4021 5777 C0440  
09 22 4021 5777 C0440  
09 24 4021 5777 C0440  
09 25 4021 5777 C0440  
09 26 4021 5777 C0440  
09 20 4027 5777 C0643  
09 21 4021 5777 C0643  
09 22 4021 5777 C0643  
09 25 4021 5777 C0643  
09 26 4021 5777 C0643  
09 25 4021 5777 C0715  
09 26 4021 5777 C0715

DRG 2023-3 On Call Drainage Improvements At Various Locations					
Bid Items	ITEM/DESCRIPTION	UNIT	UNIT PRICES	BID QTY	AMOUNT IN FIGURES
0201002A	CLEARING AND GRUBBING	LS	\$ 3,307.50	1	\$ 3,307.50
0202453A	TEST PIT (\$1,000.00/EA MIN BID )	EA	\$ 1,102.50	20	\$ 22,050.00
0205001A	TRENCH EXCAVATION (0'-4' DEEP)	CY	\$ 0.01	1000	\$ 11.03
0205002A	ROCK IN TRENCH EXCAVATION (0'-4' DEEP)	CY	\$ 192.94	50	\$ 9,646.88
0205003A	TRENCH EXCAVATION (0'-10' DEEP)	CY	\$ 49.61	750	\$ 37,209.38
0205004A	ROCK IN TRENCH EXCAVATION (0'-10' DEEP)	CY	\$ 192.94	50	\$ 9,646.88
0205005A	TRENCH EXCAVATION (0'-15' DEEP)	CY	\$ 121.28	100	\$ 12,127.50
0205006A	ROCK IN TRENCH EXCAVATION (0'-15' DEEP)	CY	\$ 220.50	30	\$ 6,615.00
0213012	GRANULAR FILL	CY	\$ 27.56	100	\$ 2,756.25
0213013A	3/4" CRUSHED & WASHED STONE BASE	CY	\$ 38.59	100	\$ 3,858.75
021911A	SEDIMENTATION CONTROL AT CATCH BASIN	EA	\$ 137.81	20	\$ 2,756.25
0304002	PROCESSED AGGREGATE BASE	CY	\$ 16.54	500	\$ 8,268.75
0406004A	3" TEMPORARY PAVEMENT REPAIR	SY	\$ 55.13	1500	\$ 82,687.50
0406009A	5" TEMPORARY PAVEMENT REPAIR	SY	\$ 82.69	100	\$ 8,268.75
0406201A	ROAD ENCROACHMENT PERMANENT PAVEMENT REPAIR (MAJOR ARTERIAL)	SY	\$ 148.84	50	\$ 7,441.88
0406202A	ROAD ENCROACHMENT PERMANENT PAVEMENT REPAIR (MINOR ARTERIAL)	SY	\$ 104.74	50	\$ 5,236.88
0406203A	ROAD ENCROACHMENT PERMANENT PAVEMENT REPAIR (COLLECTOR)	SY	\$ 103.64	50	\$ 5,181.75
0406204A	ROAD ENCROACHMENT PERMANENT PAVEMENT REPAIR (LOCAL)	SY	\$ 77.18	50	\$ 3,858.75
0507001A	TYPE 'C' CATCH BASIN	EA	\$ 3,858.75	20	\$ 77,175.00
0507007A	TYPE 'C' CATCH BASIN TOP	EA	\$ 1,543.50	20	\$ 30,870.00
0507042A	RESET CATCH BASIN	EA	\$ 1,378.13	10	\$ 13,781.25
0507105A	CONNECTION TO EXISTING MANHOLE, CATCH BASIN OR DRYWELL	EA	\$ 606.38	15	\$ 9,095.63
0507493	MANHOLE - 48" DIAMETER	EA	\$ 4,410.00	3	\$ 13,230.00
0507781	RESET MANHOLE	EA	\$ 992.25	3	\$ 2,976.75
0507829	CONVERT MANHOLE TO TYPE 'C' CATCH BASIN	EA	\$ 3,031.88	3	\$ 9,095.63
0507831	CONVERT CATCH BASIN TO MANHOLE	EA	\$ 3,031.88	3	\$ 9,095.63
0507869A	TYPE 'C' CATCH BASIN DOUBLE GRATE - TYPE I STRUCTURE WITH MANHOLE FRAME AND COVER	EA	\$ 6,063.75	3	\$ 18,191.25
0507870A	TYPE 'C' CATCH BASIN DOUBLE GRATE - TYPE II STRUCTURE WITH MANHOLE FRAME AND COVER	EA	\$ 6,063.75	3	\$ 18,191.25
0507903	DRYWELL	EA	\$ 6,615.00	3	\$ 19,845.00
0651001A	BEDDING MATERIAL	CY	\$ 38.59	750	\$ 28,940.63
0651716	10" DUCTILE IRON PIPE	LF	\$ 132.30	20	\$ 2,646.00
0651754	6" PVC - STORM PIPE	LF	\$ 77.18	75	\$ 5,788.13
0686000 12	12" RCP (CLASS IV)	LF	\$ 97.02	50	\$ 4,851.00
0686000 15	15" RCP (CLASS IV)	LF	\$ 99.23	50	\$ 4,961.25
0686000 18	18" RCP (CLASS IV)	LF	\$ 102.53	50	\$ 5,126.63
0686000 24	24" RCP (CLASS IV)	LF	\$ 115.76	50	\$ 5,788.13
0686000 36	36" RCP (CLASS IV)	LF	\$ 159.86	50	\$ 7,993.13
0686000 42	42" RCP (CLASS IV)	LF	\$ 192.94	50	\$ 9,646.88
0686230 08	8" CORRUGATED P.E. PIPE (SMOOTH INTERIOR)	LF	\$ 80.48	75	\$ 6,036.19
0686230 12	12" CORRUGATED P.E. PIPE (SMOOTH INTERIOR)	LF	\$ 82.69	500	\$ 41,343.75
0686230 15	15" CORRUGATED P.E. PIPE (SMOOTH INTERIOR)	LF	\$ 87.10	1500	\$ 130,646.25
0686230 18	18" CORRUGATED P.E. PIPE (SMOOTH INTERIOR)	LF	\$ 99.23	500	\$ 49,612.50
0686230 24	24" CORRUGATED P.E. PIPE (SMOOTH INTERIOR)	LF	\$ 132.30	500	\$ 66,150.00
0686230 36	36" CORRUGATED P.E. PIPE (SMOOTH INTERIOR)	LF	\$ 165.38	150	\$ 24,806.25
0686801	PRECAST CONCRETE INFILTRATION GALLERY (4'X4')	LF	\$ 303.19	75	\$ 22,739.06
0751712	8" UNDERDRAIN	LF	\$ 77.18	75	\$ 5,788.13
0751713	12" UNDERDRAIN	LF	\$ 82.69	75	\$ 6,201.56
0815001	BITUMINOUS CONCRETE LIP CURBING	LF	\$ 6.62	750	\$ 4,961.25
0922001A	BITUMINOUS CONCRETE SIDEWALK	SY	\$ 66.15	100	\$ 6,615.00
0922501A	BITUMINOUS CONCRETE DRIVEWAY	SY	\$ 66.15	100	\$ 6,615.00
0944003A	FURNISHING AND PLACEING TOPSOIL	SY	\$ 9.37	250	\$ 2,342.81
0950003A	TURF ESTABLISHMENT (LAWN)	SY	\$ 1.54	250	\$ 385.88
0970006A	TRAFFICPERSON (MUNICIPAL POLICE OFFICER)	ALLOW	\$ 110,250.00	1	\$ 110,250.00
0970007A	TRAFFICPERSON (UNIFORMED FLAGGER)	HOURS	\$ 69.46	500	\$ 34,728.75
0971001A	MAINTENANCE AND PROTECTION OF TRAFFIC	LS	\$ 5,512.50	1	\$ 5,512.50
0975003A	MOBILIZATION	EA	\$ 3,858.75	10	\$ 38,587.50
0980002A	PROJECT SURVEY AND STAKEOUT	LS	\$ 5,512.50	1	\$ 5,512.50
1000000A	RELOCATION OF EXISTING UTILITIES	ALLOW	\$ 27,562.50	1	\$ 27,562.50
<b>TOTAL</b>					<b>\$ 1,124,616.15</b>



## Contract Staff Summary

<b>Department/Staff Contact</b>	DPW Thomas Szabo Waste Programs Manager
<b>Common Council Committee</b>	Public Works Committee
<b>Date Approved by Committee</b>	
<b>Purpose/Scope</b>	1 <sup>st</sup> Amendment – Municipal Solid Waste Disposal Consulting Services
<b>Vendor</b> (Indicate if new or existing vendor)	NewGen Strategies and Solutions, LLC
<b>Term of Contract</b>	
<b>Method of Procurement</b> (Indicate if sole source)	Bid
<b>Cost of Contract</b>	\$33,300.00
<b>Funding Source/Account Number</b>	01 40 43 5298
<b>Additional Information/Other Details</b>	



CITY OF NORWALK  
**Thomas Szabo**  
*Waste Programs Manager*  
15 South Smith Street  
Norwalk, CT 06855  
Office: (203) 854-3215  
www.norwalkct.gov  
Tszabo@norwalkct.gov

To: Vanessa Valadares, P.E. – Chief of Operations and Public Works  
From: Thomas Szabo, Waste Programs Manager  
CC: Chris Torre, Superintendent of Operations  
Subject: Municipal Solid Waste Disposal Consulting Services Contract Amendment  
Date: January 29<sup>th</sup>, 2026

The City of Norwalk’s contract with NewGen Strategies and Solutions, LLC for Project No. 4277 Municipal Solid Waste Disposal Consulting Services has proven to be very beneficial in the process of evaluating the City’s waste programs, assisting with waste service procurement, and the long-term planning associated with the development of a waste management plan as part of their contract. Based on the success of the food scrap pilot program and the formal adoption as a program necessitates the opportunity to develop a program plan that will ensure the City maximizes the cost savings to residents and benefits to the local environment. It is my recommendation that the City of Norwalk amend this contract to include Services for Food Waste Procurement Assistance.

I would like to request the following item be included on the agenda for the February 2026 Public Works Committee meeting.

1. Authorize the Mayor, Barbara C. Smyth, to execute the 1st Amendment to the July 20th, 2023 agreement between the City of Norwalk and NewGen Strategies and Solutions, LLC for Municipal Solid Waste Disposal Consulting Services for a sum not to exceed \$33,300.

Account No. 0140435298

Sincerely,

Thomas Szabo

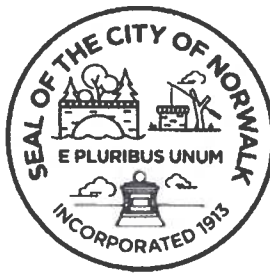

DEPT OF FINANCE - Purchasing Department

**NONCOMPETITIVE PROCUREMENT JUSTIFICATION FORM**

DATE: 1/28

DEPARTMENT: Public Works Operations

Procurement by non-competitive proposals may be used only when the award of a contract is infeasible under informal competitive Quotations (§3-204), Informal Competitive Request for Proposals (§3-205), seal bids, or competitive proposals and at least one of the following circumstances applies:

Check One:

<input checked="" type="checkbox"/>	1	The item is available only from a single source (justification is attached). The provisions of this regulation apply to all sole source procurements unless emergency conditions exist as defined by Purchasing Guideline on Emergency Procurements
<input type="checkbox"/>	2	After solicitation of several sources, competition is determined inadequate (record of source contacts and/or attempts to obtain pricing is attached)
<input type="checkbox"/>	3	The compatibility of equipment, accessories, or replacement parts is of paramount consideration
<input type="checkbox"/>	4	The item/service is available on a Cooperative Purchasing Agreement (please provide the organization name, quote, and the contract/agreement number)
<input type="checkbox"/>	5	The public exigency or emergency for the requirement will not permit a delay resulting from competitive solicitation (documented emergency contingency is attached). <b>Please forward this form and supporting documentation within 48 hours of the Emergency</b>
<input type="checkbox"/>	6	Other, please explain:

TOTAL COST: \$33,300 MUNIS Account: 0140435298

VENDOR: NewGen Strategies & Solutions, LLC

Sharon  
Connors  
rs

Purchasing Agent Signature	The Purchasing Agent		Department Head Signature
Digitally signed by Sharon Connors	<input checked="" type="checkbox"/>	Supports	
Purchasing Agent Name	<input type="checkbox"/>	Does Not Support	Department Head Name
Date: 2026.01.28 15:45:02 -05'00'	<input checked="" type="checkbox"/>	Single Source Requires Common Council Authorization (in excess of \$20,000.00)?	Vanessa Valadares Date: 1-28-26

**JUSTIFICATION:**

NewGen Strategies & Solutions, LLC was selected as the City's consultant for Municipal Solid Waste Disposal Consulting Services through an RFP issued in April 2023. Since that time, NewGen has supported the City's efforts to evaluate existing solid waste programs and develop recommendations for operational and service improvements.

As part of the City's Solid Waste Management Plan, Norwalk is seeking to enhance and expand its food scrap program. The City proposes to engage NewGen to further evaluate available options and provide targeted recommendations for this initiative. Given NewGen's extensive familiarity with Norwalk's solid waste systems, extending their scope of work is both efficient and cost-effective.

**ANY OTHER VENDORS CONTACTED FOR PRICING? (Please attach quotes):** \_\_\_\_\_

**Vendor 1:** \_\_\_\_\_

**Vendor 2:** \_\_\_\_\_

**EMERGENCY:** Explain in detail the nature of the emergency

January 28, 2026  
via email to [Vvaladares@norwalkct.gov](mailto:Vvaladares@norwalkct.gov)

Ms. Vanessa Valadares, PE  
Chief of Operations and Public Works  
City of Norwalk, Connecticut

**Subject: Proposal for Food Waste Procurement Assistance**

Dear Ms. Valadares:

NewGen Strategies and Solutions, LLC (NewGen) appreciates the opportunity to continue offering our consulting services to the City of Norwalk. With the Solid Waste Strategic Plan complete, initiatives to implement the Strategic Plan can begin. Per recent discussions, the City is interested in issuing a request for proposals for food waste collection and processing, which is in-line with the Strategic Plan's recommendation to make the food waste pilot program a permanent program in the City, given the pilot program's success. The purpose of this letter proposal is to describe the proposed scope of services, estimated fees, and timing to assist the City with the food waste procurement.

## PROPOSED SCOPE OF SERVICES

### Task 1: Project Kickoff and Management

Because the NewGen Team already has a thorough understanding of the City's current practices, this task will be limited to gathering updated data specifically related to the food waste program. The up-to-date data will assist with developing the background section of the procurement package described in Task 2. We will meet with the City's project management team and appropriate City personnel, as needed.

It is anticipated that the general approach to the procurement process followed in the conduct of the collection and transfer station operations RFP will be used again for this food waste procurement. NewGen will coordinate with the City's purchasing personnel as needed and directed by the City throughout this engagement.

#### *NewGen Team Responsibilities:*

- Prepare and provide data request for updated metrics, expected to be limited in scope
- Facilitate virtual meetings with appropriate City personnel as necessary

#### *City Responsibilities:*

- Provide the NewGen Team with relevant information in response to the data request
- Provide feedback during virtual meetings

### Task 2: Draft Procurement Package Sections

The NewGen Team will draft the background, scope, and pricing form sections of the procurement documents and provide a high-level review of other sections of the RFP as needed. We anticipate working closely with the City's Purchasing Department representatives to draft the appropriate sections of the RFP

using the City's standard templates. As members of the NewGen Team are not attorneys, it will ultimately be the City's responsibility to conduct final legal/policy review of the procurement package and release the RFP.

*NewGen Team Responsibilities:*

- Prepare and provide up to three drafts of the background, scope, and pricing form sections of the procurement package, incorporating City comments into each draft, via email
- Participate in conference calls, as necessary, to discuss review comments from the City for each draft

*City Responsibilities:*

- Provide timely review of each draft of the background, scope, and pricing form sections of the procurement package, consolidating comments from multiple reviewers
- Participate in conference calls, as necessary, to discuss comments on each draft
- Finalize and release the RFP

### Task 3: Estimate Cost of Theoretical In-house Service

The NewGen Team will develop high-level cost estimates of the City bringing collection and processing of food waste in-house, meaning performed by City personnel. It is assumed this would include the City collecting from the current three (and potentially more) drop-off sites and purchasing and operating a form of in-vessel composting. The NewGen Team will work with the City to develop appropriate assumptions for the theoretical in-house services, as needed. The NewGen Team will conduct internet research, interview equipment providers as needed, and potentially interview other jurisdictions that perform these services in-house, if available. The NewGen Team will develop reasonable cost estimates for the City to perform these services and will provide a summary memorandum of results. The results may be used to compare with results of the procurement process to determine the best approach for the City.

*NewGen Team Responsibilities:*

- Coordinate with the City on assumptions, as needed
- Conduct internet research and interviews
- Develop high-level cost estimates for theoretical in-house services
- Provide summary memorandum

*City Responsibilities:*

- Participate in conference calls, as necessary, to discuss assumptions and research
- Provide timely review of summary memorandum

### Task 4: Additional Services

NewGen Team staff are available to assist the City throughout the procurement process. This assistance may include assistance with the pre-proposal meeting, reviewing proposals received in response to the RFP for technical content, assistance with evaluation committee meetings, or other items that may arise. Any additional services outside the scope of work identified in Tasks 1 through 3 above will be finalized at the time of the City's request. NewGen will not begin any additional services without the request and written approval of the City.

## Timing

NewGen understands the City intends to initiate these efforts as soon as possible. NewGen is available to begin the work immediately following notice to proceed from the City. It is anticipated that assistance with the procurement package development (Tasks 1 and 2) could be completed in 60 days, depending on the Purchasing Department schedule. NewGen can concurrently work on the cost estimates of Task 3, and the resulting summary memorandum can be completed in advance of receiving proposals in response to the RFP.

## Budget

The following table summarizes the estimated fees for Tasks 1 through 3 based on NewGen's understanding of the services requested by the City and the scope of services described above. The budget estimate is inclusive of labor hours; no travel expenses are included as all meetings described in Tasks 1 through 3 would be attended by NewGen virtually. For Task 4, Additional Services, the specific scope and budget would be determined at the time of the request; however, a \$10,000 contingency is requested for potential additional services, as a placeholder. All services provided by the NewGen Team will be billed with a monthly invoice submitted for the stated services including a percentage completed by task summary.

**Table 1  
Proposed Budget**

Task	Description	Task Fees
1	Project Kickoff and Management	\$3,200
2	Draft Procurement Package Sections	\$7,100
3	Estimate Cost of Theoretical In-House Service	\$13,000
	<b>Total Tasks 1 through 3</b>	<b>\$23,300</b>
4	Additional Services	\$10,000
	<b>Total Tasks 1 through 4</b>	<b>\$33,300</b>

NewGen appreciates the opportunity to continue to assist the City of Norwalk, and we look forward to working with you during this engagement. On review, should you have any questions, please feel free to contact me at (407) 247.2370 or via email at [atrulock@newgenstrategies.net](mailto:atrulock@newgenstrategies.net).

Sincerely,

**NewGen Strategies and Solutions, LLC**



Allison Trulock

Managing Director – Solid Waste

# City of Norwalk Department of Public Works



## 2025 Metrics

(January to December)



DEPARTMENT OF  
PUBLIC WORKS

# PAVING PROGRAM 2025

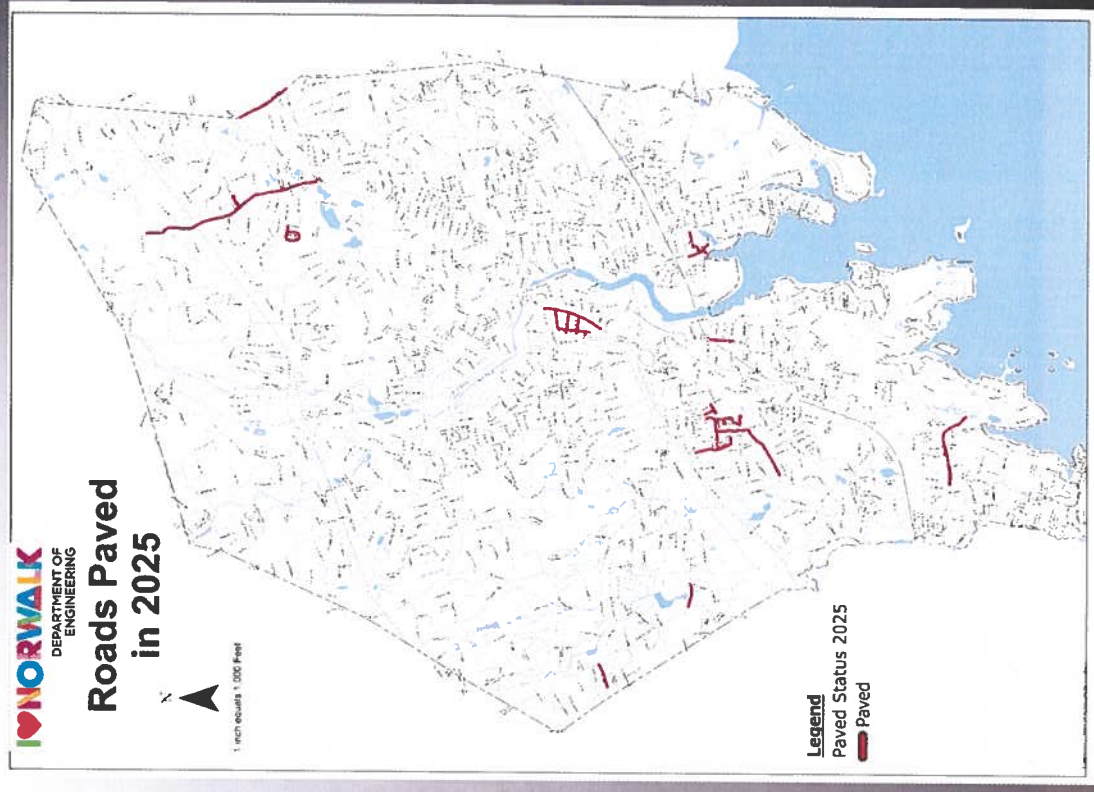

<b>Streets Paved in 2025</b>	
Number of Roads	23
Linear Ft Paved	34,574.25 ft
Center Lane Miles Paved	6.55 mi



**Grumman Avenue**  
Paved

## Comparison from 2024 to 2025

Number of Roads	-39%
Linear Ft Paved	-40%
Center Lane Miles Paved	-40%

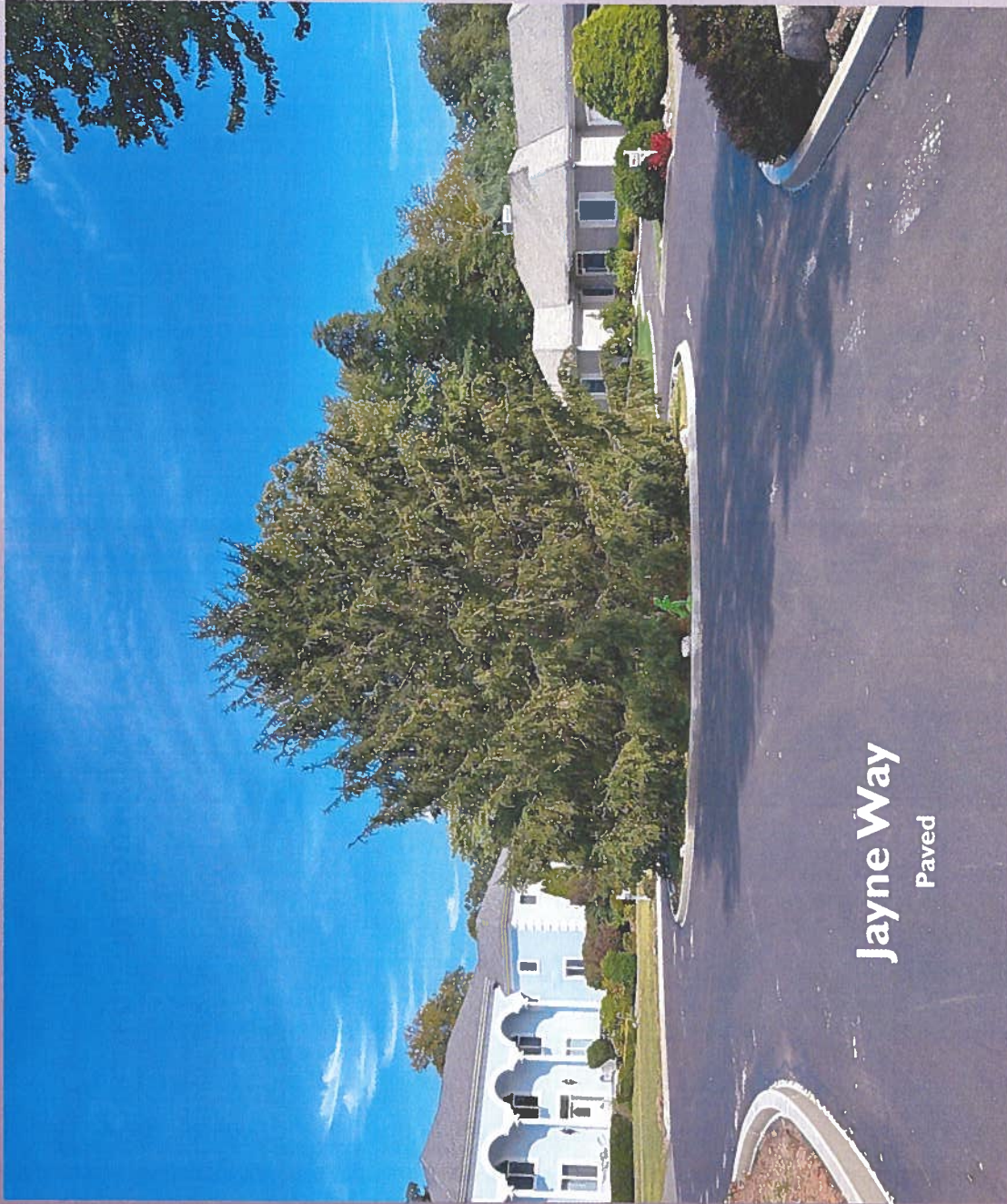

## Completed Asphalt Sidewalks 2025

Street Name	LF	Miles
Witch Lane (Highland Ave to Wilson Ave)	2,302	.44 mi
West Cedar Street (West Norwalk Road to Beechwood Drive – West Intersection)	610	.12 mi
Grumman Avenue	11,007.70	2.08 mi
Jayne Way	155	.03 mi
Heritage Hill	1,692.50	.32 mi
Witch Lane (Highland Ave to Bittersweet)	1,583.25	.30 mi
<b>Total 2025</b>	<b>17,350.45 LF</b>	<b>3.29 mi</b>



## Grumman Avenue Sidewalks



Completed Concrete Sidewalks 2025		
	LF	Miles
Totals	13,232 ft	2.51 mi

**Flax Hill Road**  
Curbs & Sidewalks



## Flax Hill Road

### Curbs & Sidewalks

(Highland Avenue to Arbor Drive)

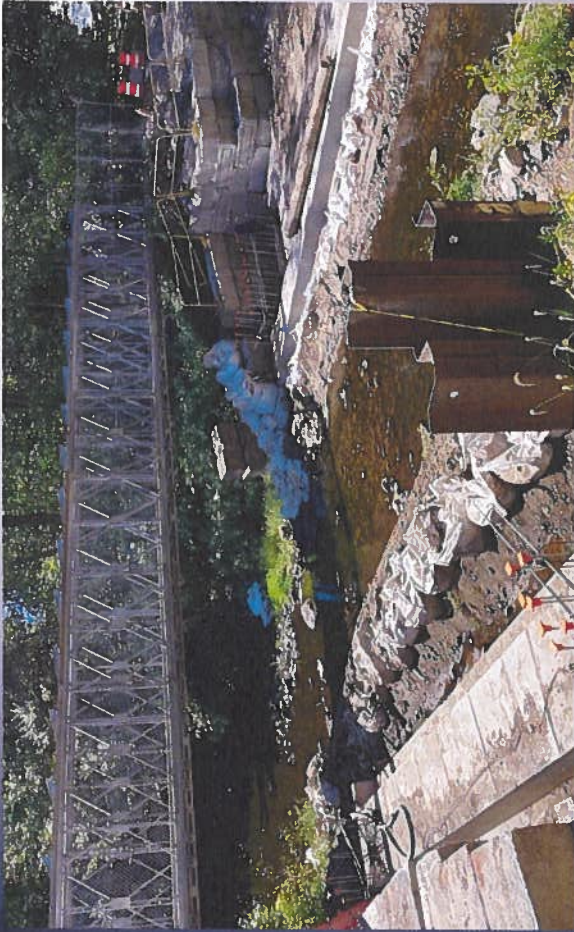

Completed Bridges in 2025	
Totals	2

## West Cedar Street Bridge



### Bridge Replacement

West Cedar Street Over Five Mile River – Bridge 0452	\$4,80,000*
--	-------------

\* State and Federally Funded

### Bridge Maintenance

Perry Avenue Bridge Rail Painting	150 L.F.	\$107,101
Perry Avenue Over Silvermine River		

## West Cedar Street Bridge

# DPW Permits

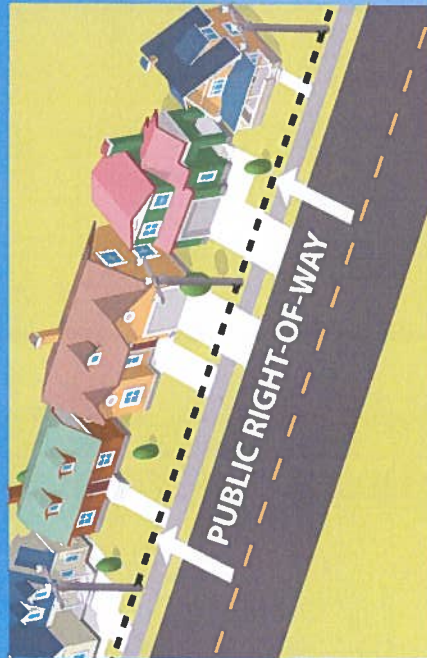

Year	Plans Approved	Plans Reviewed
2021	47	N/a
2022	41	N/a
2023	92	127
2024	64	85
2025	159	178

Permits For 2025	
Encroachment Permits Issued	478
Driveway Permits Issued	110
Sanitary Permits Issued	65
Tree Permits Issued	1
Fill Excavation Permits Issued	3
Total Number of Permits Issued	657

# Drainage

Over \$4,874,000 in improvements

Over 1,814 Feet of New Pipe installed

Installed 23 New Catch Basin Structures

7 Storm Catch Basins disconnected from the Sanitary Sewer

Heather & Lockwood Area  
Storm Drainage Improvement



25,076 linear feet of  
pipes were video  
inspected this year.



CCTV Truck



# Solid Waste 2025

Pounds of Food Scraps Dropped-Off	241,800 lbs
Tons of Recycling	7,771 tons
Tons of Yard Waste Collected	5,490 tons
Tons of Solid Waste Collected at the Transfer Station	25,539 tons
Tons of Solid Waste Curb Collected	14,022 tons
Tons of Bulky Waste Collected	168.42 tons
Number of Bulky Waste Collections	8 / 1,275 stops

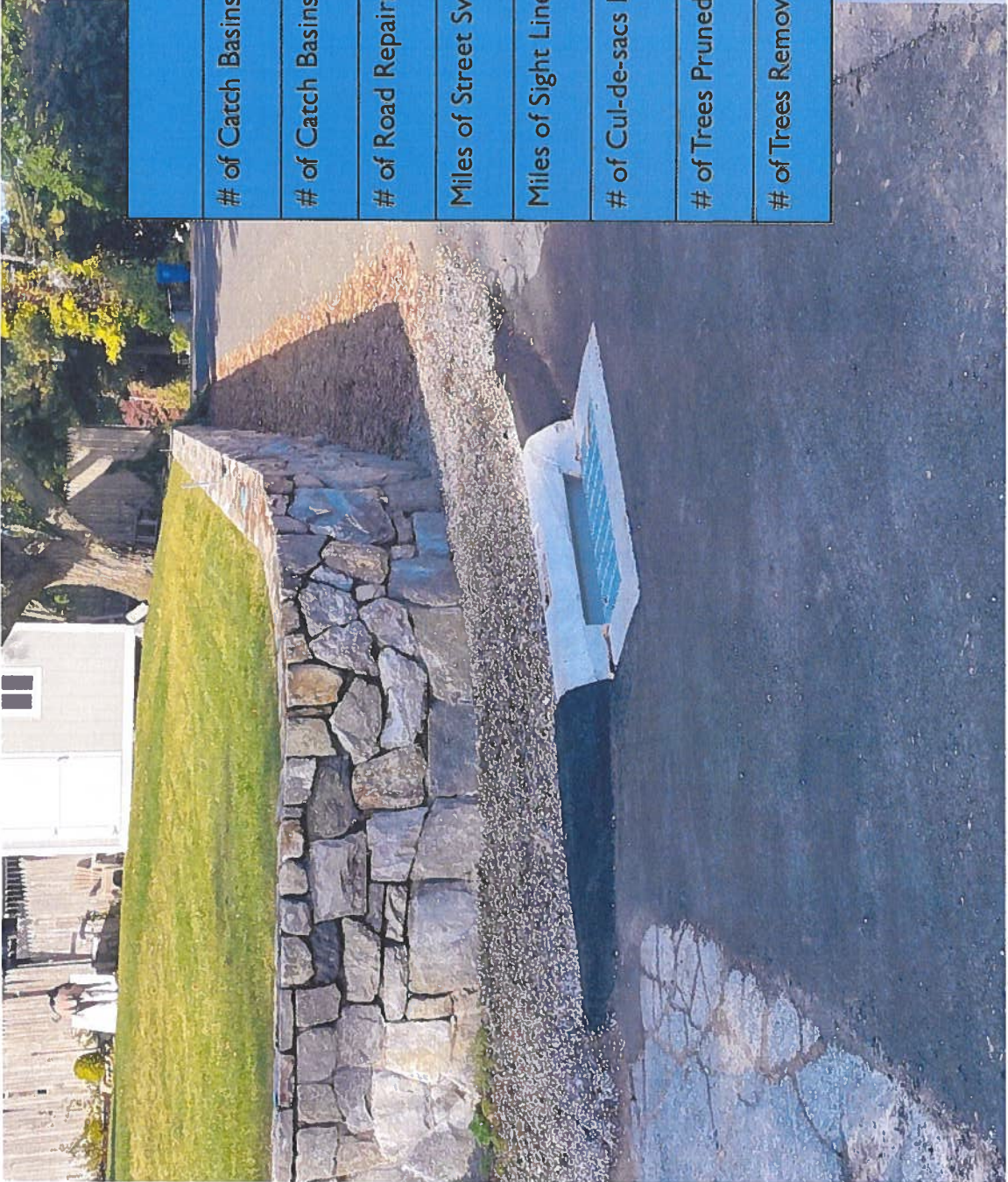

## Operations 2025

# of Catch Basins Cleaned and Inspected	1,126
# of Catch Basins Repaired or Replaced	59
# of Road Repairs	1,303
Miles of Street Sweeping	8,182 mi
Miles of Sight Lines Cleared	71 mi
# of Cul-de-sacs Mowed	234 / Twice per year
# of Trees Pruned	136
# of Trees Removed	92

# Developing Norwalk's Urban Forestry Program

## Adoption of Norwalk's Tree Master Plan

### Master Plan – April 2025

Current Canopy Cover	43% (2021)
Canopy Goal	53% by 2053
City-wide Planting Goal	2,200 trees/year on average
City-led Plantings	70%
Community-led Plantings	20%
Development-led Plantings	10%

Shaping a shared commitment to Norwalk's natural resources

# Norwalk's Tree Master Plan

A 30-year vision to grow a cooler, healthier, and greener city.

## TREE PLANTING PRIORITY MAP

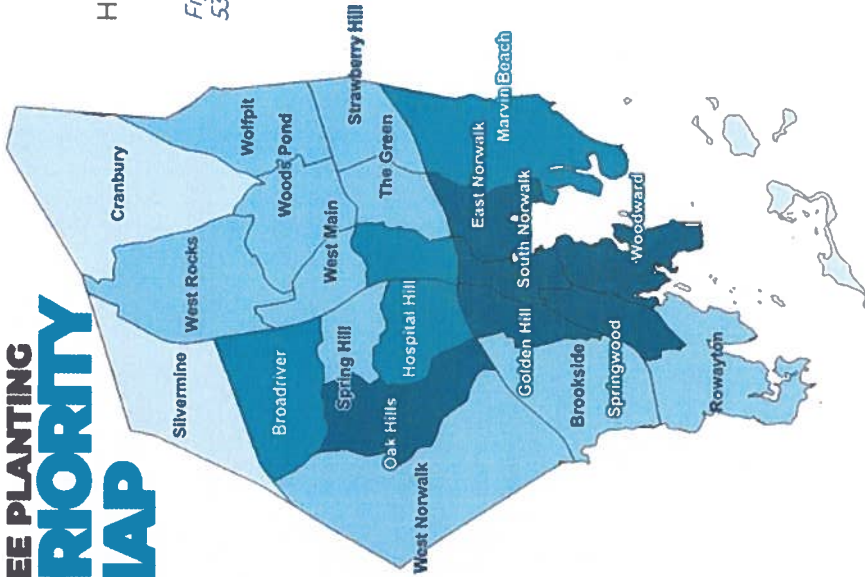

### Planting Priority Scale

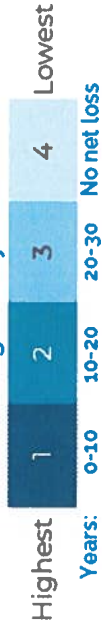

Years: 0-10    10-20    20-30    No net loss

Figure 38. Map displaying the priorities for planting toward the 53% canopy cover goal



## City-led Tree Plantings from 2020 – 2025

2020	74
2021	101
2022	401
2023	521
2024	454
2025	312



**Earth Day 2025  
On the Norwalk Green**

# Public Tree Inventory

2023 – Sample Inventory of 4,190 tree sites completed

2025 – Completed Public Tree Inventory of 25,000 tree sites completed

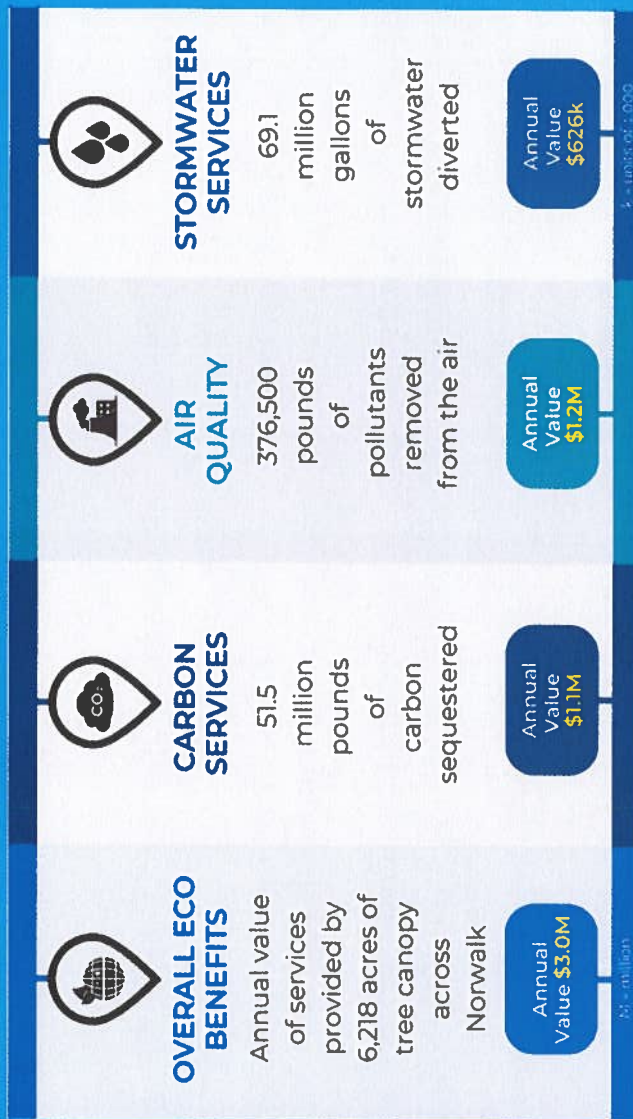



**DEPARTMENT OF  
PUBLIC WORKS**



CITY OF NORWALK  
**Jose Ortiz**  
Road Supervisor & Deputy Tree  
Warden  
jortiz@norwalkct.org  
15 South Smith Street  
Norwalk, CT 06855

## MEMORANDUM

---

**TO:** Chris Torre, Highway Superintendent & Tree Warden  
**FROM:** Jose Ortiz, Road Supervisor & Deputy Tree Warden  
**DATE:** November 1, 2025, through November 30  
**RE:** November 1, 2025, through November 30– Monthly Tree Status Report

---

### **Monthly Tree Status Report**

Monthly summary report for maintenance activities, including removals, pruning and storm debris cleanups completed during November 1 through November 30.

### **Summary**

- **Safety and Maintenance: Service Requests:** Total of (00) addressed prioritizing hazardous conditions and routine maintenance schedules to reduce risk to the public and property.

### **Detailed Metrics**

- **Total Trees Removed Parks & Recs Property: 14**
  - **Locations:**
    - 18 Pine Hill Ave
    - Nathaniel Ely Elementary
    - 10 Crooked Trail Rd
    - 382 Highland Ave
    - 21 Hollow Tree Rd
    - 300 Grumman Ave

- 7 Canfield Ave
  
- **Total Trees Pruned Parks & Recs Property: 20**

- **Locations:**

- Nathaniel Ely Elementary
- 201 Highland Ave
- Calf Pasture Beach Rd
- 25 Calf Pasture Beach
- 34 Midrocks Dr

- **Total Trees Removed City Right-of-Way: 19**

- **Locations:**

- Watering La
- 28 Duck Pond Rd
- 161 Woodward Ave
- 1 Garfield St
- 5 Ox Yoke La
- 31 Walter Ave
- 4 Jomar Rd
- 228 W Rocks Rd
- 94 Soundview Ave
- 52 Crooked Trail
- 16 Alden Ave
- 9 Cavray Rd
- 184 Woodward Ave

- **Total Trees Pruned City Right-of-Way: 14**

- **Locations:**

- 22 W Main St
- 117 Ward St
- 150 Richards La

- 1 Garfield St
- 280 Grumman Ave
- 546 West Ave
- 5 Field St
- 19 Highbrook Rd
- 4 Senga Rd
- 19 Highbrook Rd

**Storm Cleanup:**

**1. Debris Removal from Storm Cleanup or High Wind Event**

- a. Date of High Wind Event (10/30 & 10/31) Rain Event (10/30 & 10/31)
- b. Tree debris: 26 Locations
- c. Storm Date (10/30 & 10/31) Minor
- d. **Locations:**

- E Rocks Rd
- 7 Hillcrest Pl
- 2 Penny La
- 21 Hollow Tree Rd
- Twin Ledge Rd
- 53 Silvermine Ave
- 24 Olmstead Pl
- 2 Penny La
- E Rocks Rd
- 18 Pine Hill Ave
- 7 Hillcrest Pl
- 9 Stonecrop Rd
- 16 Bayview Ave
- Norden Pl & Greenfield Rd
- 13 Union Ave
- 27 Friendly Rd
- 16 Hendricks Ave
- Maple St & Stuart Ave
- 6 Tally Dr
- 16 Bayview Ave
- Norden La / Greenfield Rd

- 13 Union Ave
- 27 Friendly Rd
- 16 Hendricks Ave
- Maple St / Stuart Ave
- 6 Tally Dr

## **2. Tree Stump Grinding**

- a. Parks Property: 0 Stumps
- b. City Right-of-Way: 3 Stumps

### **Summary of Work Completed by Contractor (Almstead Tree & Shrub Care Co.)**

- **Total Trees Removed: 16**
  - **Locations:**
    - 382 Highland Ave – Brookside School
    - 21 Hollow Tree Rd – Flax Hill Park
    - 300 Grumman Ave
    - 15 Observatory Pl – Done by Utility Company
    - 36 Nursery St



CITY OF NORWALK  
**Jose Ortiz**  
Road Supervisor & Deputy Tree  
Warden

jortiz@norwalkct.org  
15 South Smith Street  
Norwalk, CT 06855

## MEMORANDUM

---

**TO:** Chris Torre, Highway Superintendent & Tree Warden

**FROM:** Jose Ortiz, Road Supervisor & Deputy Tree Warden

**DATE:** December 1, 2025, through December 31

**RE:** December 1, 2025, through December 31 – Monthly Tree Status Report

---

### **Monthly Tree Status Report**

Monthly summary report for maintenance activities, including removals, pruning and storm debris cleanups completed during December 1 through December 31.

### **Summary**

- **Safety and Maintenance: Service Requests:** Total of (30) addressed prioritizing hazardous conditions and routine maintenance schedules to reduce risk to the public and property.

### **Detailed Metrics**

- **Total Trees Removed Parks & Recs Property: 1**
  - **Locations:**
- 35 Maher Dr
- **Total Trees Pruned Parks & Recs Property: 3**
  - **Locations:**

- Calf Pasture Beach
  
- **Total Trees Removed City Right-of-Way: 2**
  - **Locations:**
    - 23 Granite Dr
    - 229 East Rocks Rd
    - 4 Scott St
  
- **Total Trees Pruned City Right-of-Way: 10**
  - **Locations:**
    - 382 Highland Ave

**Storm Cleanup:**

1. **Debris Removal from Storm Cleanup or High Wind Event**
  - a. Date of High Wind Event (12/19) Rain Event (12/19)
  - b. Tree debris: 21 Locations
  - c. Storm Date (12/19) Minor
  - d. **Locations:**
    - 30 Muller Ave
    - 173 East Rocks Rd
    - 61 East Rocks Rd
    - Calf Pasture Beach
    - 4 Scott St
    - 223 Strawberry Hill Rd
    - 337 Highland Ave
    - 167 Highland Ave
    - 42 Toilsome Ave
    - 18 Stephen Mather Rd
    - 31 Nursery St
    - 29 Apple Tree La

- 176 Strawberry Hill Rd
- 11 Creeping Hemlock Dr
- 9 Creeping Hemlock Dr
- 50 Sammis St
- 29 Keeler Ave
- Cossitt Rd & Chatham Dr
- 192 Grumman Ave
- 75 Strawberry Hill
- 25 Calf Pasture Beach

## **2. Tree Stump Grinding**

- a. Parks Property: 1 Stumps
- b. City Right-of-Way: 2 Stumps

### **Summary of Work Completed by Contractor (Almstead Tree & Shrub Care Co.)**

- **Total Trees Removed: 1**
  - **Locations:**
    - 198 West Rocks Rd
    - 168 East Rocks Rd

# Municipal Solid Waste & Recycling Report

## for Public Works Meeting

February, 3<sup>rd</sup>, 2026

### A. Municipal Solid Waste & Recycling Metrics

#### 1. November 2025 Municipal Solid Waste & Recycling Metrics

MSW Collection and Disposal			
Municipal Solid Waste (MSW)	Previous FY: Nov-24	Current FY: Nov-25	Change
<b>Curbside tonnage</b>	<b>1,173.95</b>	<b>1,027.68</b>	<b>-12.5%</b>
<b>MSW tonnage out</b>	<b>1,972.47</b>	<b>1,923.77</b>	<b>-2.5%</b>
Transfer station operating fee	\$76,650.00	\$76,500.00	-0.2%
Transport and disposal fee	\$200,896.07	\$195,935.97	-2.5%
Curbside collection fee	\$185,062.50	\$153,713.75	-16.9%
Total operating costs (less curbside)	\$277,546.07	\$272,435.97	-1.8%

MSW Consolidated Budget	
FY 25/26 Budget	\$5,403,762.00
Amount expended	\$2,257,464.28
Percent remaining	58.2%

Recycling Collection			
Recycling Collection	Previous FY: Nov-24	Current FY: Nov-25	Change
<b>Curbside tonnage</b>	<b>701.62</b>	<b>548.08</b>	<b>-21.9%</b>
<b>Transfer station tonnage</b>	<b>29.43</b>	<b>27.04</b>	<b>-8.1%</b>
<b>Total monthly tonnage</b>	<b>731.05</b>	<b>575.12</b>	<b>-21.3%</b>
Curbside collection fee	\$155,423.85	\$238,410.33	53.4%

Recycling Budget	
FY 25/26 Budget	\$3,161,367.00
Amount expended	\$1,199,835.93
Percent Remaining	62.0%

MSW and Recycling Revenues			
MSW and Recycling Revenues	Previous FY: Nov-24	Current FY: Nov-25	Change
Transfer station tip fees	\$45,662.70	\$46,576.00	2.0%
Total revenues	\$45,662.70	\$46,576.00	2.0%

## 2. December 2025 Municipal Solid Waste & Recycling Metrics

Municipal Solid Waste (MSW)	MSW Collection and Disposal		Change
	Previous FY: Dec-24	Current FY: Dec-25	
<b>Curbside tonnage</b>	<b>1,324.58</b>	<b>1,135.89</b>	<b>-14.2%</b>
<b>MSW tonnage out</b>	<b>2,325.73</b>	<b>1,780.33</b>	<b>-23.5%</b>
Transfer station operating fee	\$76,650.00	\$76,500.00	-0.2%
Transport and disposal fee	\$236,875.60	\$181,326.61	-23.5%
Curbside collection fee	\$185,062.50	\$153,713.75	-16.9%
Total operating costs (less curbside)	\$313,525.60	\$257,826.61	-17.8%

MSW Consolidated Budget	
FY 25/26 Budget	\$5,403,762.00
Amount expended	\$2,669,004.64
Percent remaining	50.6%

Recycling Collection	Recycling Collection		Change
	Previous FY: Dec-24	Current FY: Dec-25	
<b>Curbside tonnage</b>	<b>779.33</b>	<b>663.52</b>	<b>-14.9%</b>
<b>Transfer station tonnage</b>	<b>26.74</b>	<b>36.26</b>	<b>35.6%</b>
<b>Total monthly tonnage</b>	<b>806.07</b>	<b>699.78</b>	<b>-13.2%</b>
Curbside collection fee	\$146,382.07	\$238,994.05	63.3%

Recycling Budget	
FY 25/26 Budget	\$3,161,367.00
Amount expended	\$1,438,629.98
Percent Remaining	54.5%

MSW and Recycling Revenues	MSW and Recycling Revenues		Change
	Previous FY: Dec-24	Current FY: Dec-25	
Transfer station tip fees	\$45,171.98	\$46,075.00	2.0%
Total revenues	\$45,171.98	\$46,075.00	2.0%

### 3. Food Scrap Recycling Program Metrics

#### Monthly Food Scrap Program Metrics for November 2025 & December 2025

<i>Monthly Metrics</i>	<i>Transfer Station</i>	<i>Rowayton Community Center</i>	<i>Cranbury Park</i>
<i>Nov-25</i>	5,700 (lbs)	10,500 (lbs)	3,900 (lbs)
<i>Dec-25</i>	8,100 (lbs)	18,600 (lbs)	4,500 (lbs)

#### Total Monthly Tonnage

<i>Total Tonnage for Nov. 2025</i>	<i>Total Tonnage for Dec. 2025</i>
16 TONS	10 TONS

#### Cumulative Metrics for FY '25 - '26

<i>Drop-off Sites</i>	<i>lbs.</i>	<i>Tons</i>	<i>Site Contribution %</i>
<i>Transfer Station</i>	33,300	16.65	28.50%
<i>Rowayton Community Center</i>	60,600	30.3	51.80%
<i>Cranbury Park</i>	23,100	11.55	19.70%
<b>TOTAL:</b>	<b>117,000 lbs</b>	<b>58.5 TONS</b>	<b>100.00%</b>

#### 4. City Of Norwalk's Christmas Tree Collection Metrics

- Total Christmas Trees Collected: **2,501**

#### 5. Bulky Waste Collection Metrics

- ***\*There was no Bulky Waste Collection in November, 2025. Bulky Waste Collection was extended to Spring, 2026, and is expected to begin in March.***

### **B. Other Programs**

#### 1. Bulky Waste Collection Program

- Begins March 4, 2026 for Zone 1 – Residents must schedule their pick-up by calling Customer Service or by utilizing the Click & Request app, between Tuesday, February 17th – Friday, February 27<sup>th</sup>.
- Residents have the opportunity to schedule two pick-ups per year and are limited to 1-cubic yard of items. (*see attachment*)

#### 2. Norwalk's Can & Bottle Return event in partnership with EyeRecycle

- First EyeRecycle event of the year is scheduled for: *Monday, March 16<sup>th</sup>, 2026*

### **C. Education and Public Outreach**

#### 1. Events Attended

- Norwalk's Can & Bottle Return Pop-up Event in partnership with EyeRecycle
  - Shared sustainable waste management information to promote low-impact waste habits during the holiday season.
- Norwalk's 2025 Annual Holiday Extravaganza
  - Educational Materials/Activities: Holiday-themed waste reduction *Holiday "Sort It Out"* Game. Participants identified items as trash, recycling, or compost  
Estimated number of residents engaged: 89
- Public outreach materials provided at events & online (*see attached*)

- Yard Waste Site & Transfer Station Facility flyers, Yard Waste Collection, Christmas Tree Collection, NotifyMe Sign-up flyer
- Thanksgiving Food Waste Management
- Holiday Recycle Guide & Recycling Cart Placement
- New Year's Food Waste Management
- Holiday-themed Waste Reduction "*Sort It Out*" game (Garbage / Compost / Recycling)

## HOW TO PLACE YOUR CARTS

Norwalk's waste and recycling are collected at the curb using WIN Waste's automated collection trucks, a safe and efficient method for servicing your community. To help us provide the best service for your waste and recycling needs, please follow these guidelines to ensure your carts are properly placed for collection.

- Set your carts so they face the street, with lids toward the road and handles facing away from the road.
- Keep at least 3 feet between your carts and any other objects, including mailboxes, cars, trees, etc.
- Please make sure all waste and recycling is placed inside your city-provided 65-gallon carts.
- Materials left outside of carts will not be collected.
- Carts should not be painted or permanently altered.

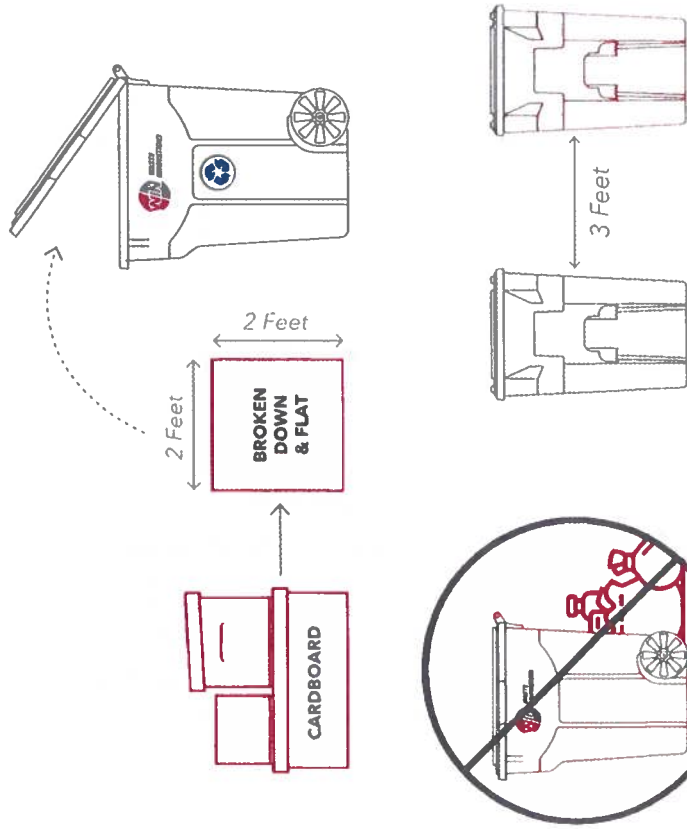

## BULKY WASTE COLLECTION

Residents of the fourth taxing district that receive weekly waste pickup are entitled to receive curbside bulky waste collection twice per year. Residents should call the City of Norwalk Customer Service Center at 203-854-3200 to schedule their bulky collection during their designated months or sign up online.

- **Zone 1:** March & July
- **Zone 2:** April & August
- **Zone 3:** May & September
- **Zone 4:** June & October

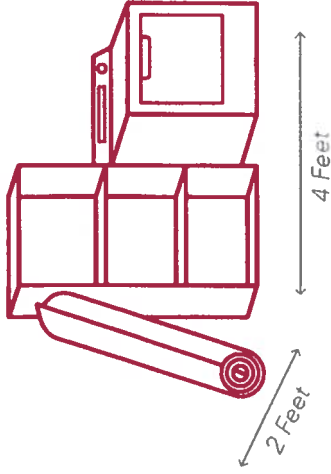

**Residents can place up to 1 cubic yard of material out for bulky collection. This is approximately 4 feet by 2 feet.**

**Acceptable Items:** Furniture (such as couches, chairs, bookcases, etc.); mattresses; rolled rugs/carpets (no more than four feet wide); metal items; metal appliances such as washing machines; dryers, dishwashers; etc. (CANNOT contain freon); and large plastic items (children's toys, outdoor chairs, etc.)

**Unacceptable Items:** Household hazardous waste; liquid waste (paint); tires; vehicles and motor parts (or anything with a title of ownership, such as motorcycles, trailers, etc.); yard waste; construction and remodeling debris (concrete, sheetrock, masonry, toilets, sinks, shingles, pipes, furnaces, fiberglass, etc.); single-stream recycling; clothing or textiles; electronics (televisions, computers, speakers, etc.); and freon appliances (air conditioners, refrigerators, dehumidifiers, etc.)

**For more information about the City of Norwalk's Bulky Waste Collection Program**, including the schedule, zoning map, and additional guidelines, visit [www.norwalkct.gov](http://www.norwalkct.gov) or contact the Customer Service Center at (203) 854-3200 or [CustomerService@norwalkct.gov](mailto:CustomerService@norwalkct.gov).

# Helpful Tips on Managing Food this Thanksgiving!

Americans throw away an estimated 320 million pounds of food on Thanksgiving which is equivalent to about \$550 million of food.

## Scraps & Trimmings



Stems, peels, bones can be saved for stock or compost. If you have garden space or a compost bin, consider home composting.

## Shop Smart & Freeze Extras

Freeze your leftovers & additional purchased food. If you do buy more, freeze parts (e.g. bread, stock, meats) before spoilage.



## Serve Buffet Style



Let guests take what they want, rather than pre plating large portions. Offer smaller serving bowls & refill as needed to avoid overfilling.

## Estimate Servings

Use online calculators to estimate how much food your guests will eat. Favor recipes that can easily scale down, or that transform leftovers.



## Where Can I Bring My Food Scraps?

- Rowayton Community Center  
at 33 Highland Ave, Norwalk
- Norwalk Transfer Station & Recycling Center  
at 61 Crescent St, Norwalk
- Cranbury Park  
at 300 Grumman Ave, Norwalk

# WHY SHOULD YOU COMPOST?

## **Cleaner kitchen with almost zero effort!**

Keeping food scraps out of your garbage means less leakage from your garbage bags and less fruit flies.

## **It keeps pests away**

Removing food scraps from the trash stops pests from recognizing your trash as a food source.

## **It makes cooking clean-up easier**

Skip the overflowing trash can that fills up too fast and assign the task of clearing plates to your designated food scrap bin.

## **Highlights money spent on wasted food**

Composting makes you notice what food you actually use and leads to less overbuying! When you put scraps in a separate bin, you recognize which foods you're constantly tossing.

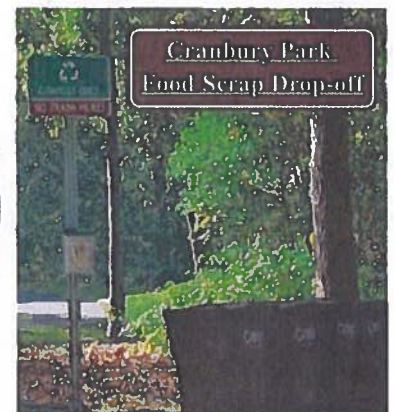

## **How to do it:**

### **1. Collect your food scraps in food scrap container**

Left over expired food, fruits, vegetables (remove stickers, bands, and ties), meat, poultry, fish (bones are ok) dairy products, bread, pasta, rice, grains, eggshells, chips, snacks, nuts, seeds, coffee grounds (paper filters are ok), tea bags (paper filters are ok; remove staples).

### **2. Transfer the food scraps into a paper or compostable bag**

### **3. Drive to the one of Norwalk's Food Scrap Drop-off Sites**



# Holiday Recycle Guide



## GARBAGE



Broken Ornaments



Wrapping Paper



Hand Warmers

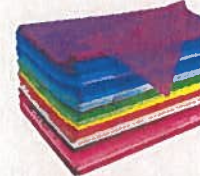

Tissue Paper



Wreaths



Wax-lined Cups



Foil



Paper Plates,  
Utensils & Napkins



Bows & Ribbons



## RECYCLE



FOLDED Cardboard Boxes



Plain Gift Boxes & Bags



Catalogs



Holiday Cards &  
Envelopes



## SPECIAL DROP-OFFS



Food Scraps

Norwalk Transfer Station  
Cranbury Park  
Rowayton Community Center



Christmas Trees

Visit the Yard Waste Site to  
drop off your Christmas Tree.

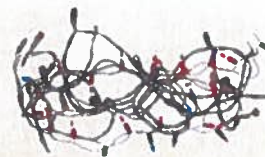

Holiday String Lights



Electronics



Batteries

Residents can also visit the Transfer Station & Recycling Center  
to drop-off holiday lights, electronics or batteries!

# Recycling Cart Placement

## WASTE CART NOT ACCESSIBLE

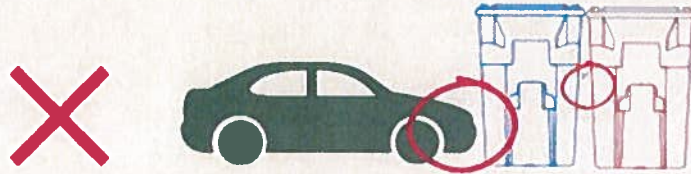

## RECYCLING OUTSIDE OF WASTE CART



## INELIGIBLE WASTE CART

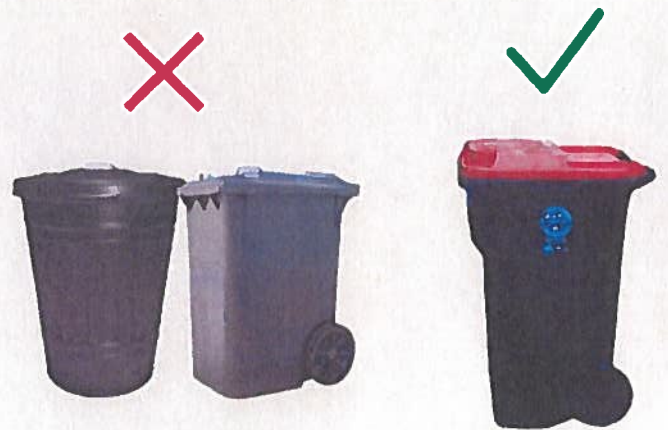

## OVERFLOW OF BAGS



## PROHIBITED ITEMS IN WASTE CART



# HELPFUL TIPS ON MANAGING FOOD THIS *new year* HOLIDAY!

## Scraps & Trimmings

Stems, peels, bones can be saved for stock or compost. If you have garden space or a compost bin, consider home composting.

## Serve Buffet-Style

Let guests take what they want, rather than pre-plating large portions. Offer smaller serving bowls & refill as needed to avoid overfilling.

## Shop Smart & Freeze Extras

Freeze your leftovers & additional purchased food. If you do buy more, freeze parts (e.g. bread, stock, meats) before spoilage.

## Estimate Servings

Use online calculators to estimate how much food your guests will eat. Favor recipes that can easily scale down, or that transform leftovers.

### Where Can I Bring My Food Scraps?

• Rowayton Community Center

at 33 Highland Ave, Norwalk

• Norwalk Transfer Station & Recycling Center

at 61 Crescent St, Norwalk

• Cranbury Park

at 300 Grumman Ave, Norwalk

## WHY SHOULD YOU COMPOST?

### Cleaner kitchen with almost zero effort!

Keeping food scraps out of your garbage means less leakage from your garbage bags and less fruit flies.

### It keeps pests away

Removing food scraps from the trash stops pests from recognizing your trash as a food source.

### It makes cooking clean-up easier

Skip the overflowing trash can that fills up too fast & assign the task of clearing plates to your designated food scrap bin.

### Highlights money spent on wasted food

Composting helps you understand what foods you waste most often & leads to less overbuying! When you put scraps in a separate bin, you recognize which foods you're constantly tossing.

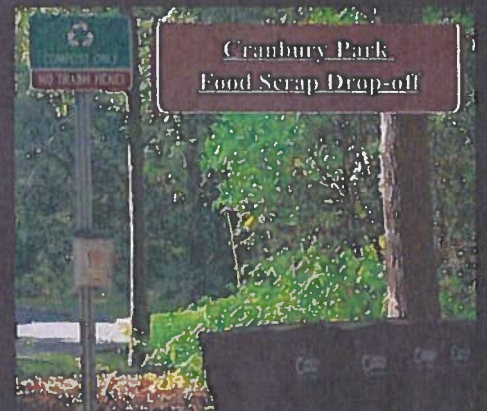

## HOW TO DO IT

### 1. Collect your food scraps in food scrap container

Left over expired food, fruits, vegetables (remove stickers, bands, and ties), meat, poultry, fish (bones are ok) dairy products, bread, pasta, rice, grains, eggshells, chips, snacks, nuts, seeds, coffee grounds (paper filters are ok), tea bags (paper filters are ok; remove staples).

### 2. Transfer the food scraps into a paper or compostable bag

### 3. Drive to the one of Norwalk's Food Scrap Drop-off Sites





DEPARTMENT OF  
ENGINEERING

**Department of Engineering – Public Works Committee Meeting – February 3, 2026**

**Current Construction:**

**RD2025-2 – Sidewalks, Drainage and Paving on Flax Hill Rd from Arbor Dr to Washington St**

This project consists of the installation of new concrete curbs, sidewalks, and roadway paving on Flax Hill Road from Arbor Drive to Washington Street. This is a joint project in conjunction with the South Norwalk Electric and Water Co (SNEW), who are currently installing a new water main with service lines.

- The contractor, Guerrero Construction is continuing work in the area. As of now, most construction is related to SNEW work. Much of the water main has been installed from Taylor Ave to Washington St. We are coordinating their construction schedule.
- ~40% of sidewalk and curb completed

**Roton Ave Drainage**

This project consists of the installation of new drainage structures on Roton from McKinley Street to Pine Point Road. This will also include the installation of green infrastructure. This is in order to alleviate roadway ponding in the area as well as the preparation of a separate sidewalk and roadway.

- The contractor, M. Rondano, Inc. began construction of new drainage structures last week. Weather permitting, they are looking to complete the work by the end of March.

**PM2025-2 - Paving at Various Locations**

This project consists of milling, reclaiming, and paving of Witch Lane (Highland to Wilson), and surrounding side streets (Old Witch Court, Old Field Road, Tory Hill Lane), including extruded concrete curb.

- Winter shutdown. Construction will reconvene in the spring when the asphalt plants are open for production.

**Design:**

**Lockwood Lane and Heather Lane Roadway Paving and Sidewalk**

This project consists of the installation of new concrete curbs, sidewalks, and roadway paving on Lockwood Lane, Heather Lane, Cory Lane, and Katy Lane. This following a recently completed



**DEPARTMENT OF  
ENGINEERING**

drainage project in the area. Our consultant, Tighe & Bond has provided plans for a feasible sidewalk layout that has been shared at a public meeting last November.

- In response to various residential objections, the consultant has submitted plans for two (2) potential alternatives. These include narrowing the sidewalk to 4' and installing asphalt sidewalks as opposed to concrete.
- We are going to hold another public session for the potential alternatives on Tuesday, February 3 at 5:30 PM.

Drainage Study for Intersection of Meadow St and South Main St

Our consultant, Langan Engineers have been retained to design a stormwater remediation system for the intersection of Meadow Street and South Main Street. This is the location of the proposed roundabout from TMP for the new school.

- As this is being coordinated with TMP's roundabout project, we are looking to advertise this in late spring for summer construction. This is in order to not interfere with school activities. Construction should take place from late June 2026 to late August 2026.

Glendenning Street and Cannon Street Area Stormwater Remediation

Our consultant, Woodard & Curran is currently designing a major stormwater system from Glendenning Street to the bridge at Cannon Street. 90% drawings are being reviewed.

- We are hopeful to begin construction should begin July, 2026. However, this will depend on the approval of all relevant federal and state permits.

New Canaan Ave/Ponus Ave Storm Drainage Improvements – Phases 1 and 2

Our consultant, Woodard & Curran is currently designing a major stormwater system at Ponus Avenue near Broad River Park. This will involve a major drainage renovation between the Broad River Park baseball field and the existing storm outfall on Nutmeg Place.

- Design is in the early stages and we are hopeful to advertise in summer 2026 with construction beginning in Fall 2026. However, this will depend on the approval of all relevant federal and state permits.
- This project would be the first in a multi-phase capital project designated to alleviate flooding in the Ponus Ave area as far as Fox Run Road.

Installation of handicap ramps in the parking lot area at City Hall

- Project is to install several new handicap ramps at city hall. The project may include a raised crosswalk from the loading dock area to the baseball field.



DEPARTMENT OF  
ENGINEERING

**Current Projects out to bid/bid received:**

**BR2026-1 - Structural Repair of Two (2) Local Bridge Rehabilitation/Preservation Projects**

In 2019, the following bridges have been evaluated by an outside consultant and determined to be in need of repair:

- Bridge No. 102-025 – Bonnybrook Trail over Holy Ghost Fathers Brook
- Bridge No. 102-029 - Bonnybrook Trail over Holy Ghost Fathers Brook.
- Construction should begin May, 2026.
- Construction should be complete by the end of August 2026.

**Project No: RD2026-1 - Roadway Paving and Sidewalk Installation for Roton Avenue and Pine Point Road (From McKinley Street to Nearwater Road)**

This project consists of the installation of new concrete curbs, sidewalks, and roadway paving on Roton Avenue and Pine Point Road from McKinley Street to Nearwater Road.

- SNEW is also looking to perform work in the area between McKinley Street to Crockett Street. We will coordinate our construction projects.
- The project was recently advertised to bid on January 23, 2026. SNEW is looking to advertise their project at the same time.
- We are hopeful for construction to begin April, 2026 and to be complete by the end of September, 2026.

**Lexington Ave Retaining Wall**

- Colonna Concrete Inc has been awarded the contract by the Public Work council.
- Pending a right-of-entry agreement from the property owner.